

Grizzly **Industrial, Inc.**®

MODEL G0637/G0638 7¹/₂ & 10 HP CYCLONE DUST COLLECTORS OWNER'S MANUAL



Model G0637



Model G0638

COPYRIGHT © MARCH, 2007 BY GRIZZLY INDUSTRIAL, INC., REVISED SEPTEMBER, 2007
**WARNING: NO PORTION OF THIS MANUAL MAY BE REPRODUCED IN ANY SHAPE
OR FORM WITHOUT THE WRITTEN APPROVAL OF GRIZZLY INDUSTRIAL, INC.**
#TS8762 PRINTED IN TAIWAN

 **WARNING!**

This manual provides critical safety instructions on the proper setup, operation, maintenance and service of this machine/equipment.

Failure to read, understand and follow the instructions given in this manual may result in serious personal injury, including amputation, electrocution or death.

The owner of this machine/equipment is solely responsible for its safe use. This responsibility includes but is not limited to proper installation in a safe environment, personnel training and usage authorization, proper inspection and maintenance, manual availability and comprehension, application of safety devices, blade/cutter integrity, and the usage of personal protective equipment.

The manufacturer will not be held liable for injury or property damage from negligence, improper training, machine modifications or misuse.

 **WARNING!**

Some dust created by power sanding, sawing, grinding, drilling, and other construction activities contains chemicals known to the State of California to cause cancer, birth defects or other reproductive harm. Some examples of these chemicals are:

- **Lead from lead-based paints.**
- **Crystalline silica from bricks, cement and other masonry products.**
- **Arsenic and chromium from chemically-treated lumber.**

Your risk from these exposures varies, depending on how often you do this type of work. To reduce your exposure to these chemicals: Work in a well ventilated area, and work with approved safety equipment, such as those dust masks that are specially designed to filter out microscopic particles.

Table of Contents

INTRODUCTION	2	SECTION 4: DESIGNING THE SYSTEM	28
Foreword.....	2	General	28
Contact Info	2	Duct Material.....	28
G0637 Machine Data Sheet	3	System Design.....	30
G0638 Machine Data Sheet	5	System Grounding	34
Identification.....	7	SECTION 5: ACCESSORIES	36
SECTION 1: SAFETY	8	SECTION 6: OPERATIONS	39
Additional Safety for Dust Collectors	10	Operation Safety	39
SECTION 2: CIRCUIT REQUIREMENTS	11	General	39
Phase Converter.....	11	Remote Control.....	39
Model G0637	12	SECTION 7: MAINTENANCE	40
440V Conversion	12	Schedule	40
Model G0638	12	Emptying Drums	40
440V Conversion	12	Cleaning Filters	40
SECTION 3: SETUP	13	SECTION 8: SERVICE	41
Setup Safety	13	Troubleshooting	41
Items Needed for Setup.....	13	Service Log.....	43
Unpacking	13	G0637 Electrical Components	44
Inventory	14	G0638 Electrical Components	45
Site Considerations.....	15	Wiring Diagrams	46
Mounting to Shop Floor	16	Parts Breakdown	50
Clean Up.....	16	Label Placement	53
Hardware Identification Chart	17	WARRANTY AND RETURNS	54
Assembly	18		
Test Run	27		

INTRODUCTION

Foreword

We are proud to offer the Model G0637/G0638 7½ and 10 HP Cyclone Dust Collectors. These machines are part of a growing Grizzly family of fine woodworking machinery. When used according to the guidelines set forth in this manual, you can expect years of trouble-free, enjoyable operation and proof of Grizzly's commitment to customer satisfaction.

The specifications, drawings, and photographs illustrated in this manual represent the Model G0637/G0638 when the manual was prepared. However, owing to Grizzly's policy of continuous improvement, changes may be made at any time with no obligation on the part of Grizzly.

For your convenience, we always keep current Grizzly manuals available on our website at **www.grizzly.com**. Any updates to your machine will be reflected in these manuals as soon as they are complete. Visit our site often to check for the latest updates to this manual!

Contact Info

If you have any comments regarding this manual, please write to us at the address below:

Grizzly Industrial, Inc.
c/o Technical Documentation Manager
P.O. Box 2069
Bellingham, WA 98227-2069
Email: manuals@grizzly.com

We stand behind our machines. If you have any service questions or parts requests, please call or write us at the location listed below.

Grizzly Industrial, Inc.
1203 Lycoming Mall Circle
Muncy, PA 17756
Phone: (570) 546-9663
Fax: (800) 438-5901
E-Mail: techsupport@grizzly.com
Web Site: <http://www.grizzly.com>





MACHINE DATA SHEET

Customer Service #: (570) 546-9663 • To Order Call: (800) 523-4777 • Fax #: (800) 438-5901

MODEL G0637 7.5 HP CYCLONE DUST COLLECTOR

Product Dimensions:

Weight 624 lbs.
 Length/Width/Height 76-3/4 x 59-7/8 x 137 in.
 Foot Print (Length/Width)..... 77 x 60 in.

Shipping Dimensions:

Box 1

Type Wood Crate
 Content..... Machine
 Weight..... 789 lbs.
 Length/Width/Height..... 90-1/4 x 39 x 42-1/2 in.

Box 2

Type Cardboard
 Content..... Filter Assembly
 Weight..... 42 lbs.
 Length/Width/Height..... 56-3/8 x 21-3/4 x 21-3/4 in.

Box 3

Type Cardboard
 Content..... Filter Assembly
 Weight..... 42 lbs.
 Length/Width/Height..... 56-3/8 x 21-3/4 x 21-3/4 in.

Electrical:

Switch.....Magnetic with Thermal Overload Protector
 Switch Voltage 220V
 Remote Control Provided..... Yes
 Cord Length 10 ft.
 Cord Gauge 10 gauge
 Recommended Circuit Size 40/20A
 Plug.....No

Motors:

Type TEFC Induction (Class F)
 Horsepower..... 7.5 HP
 Voltage 220/440V
 Prewired..... 220V
 Phase..... Three
 Amps 25/12.5A
 Speed..... 3450 RPM
 Cycle 60 Hz
 Number Of Speeds 1
 Power Transfer Direct Drive
 Bearings..... Shielded and Lubricated



Main Specifications:

Maximum CFM @ 4.3" SP.....	3468 CFM
Maximum Static Pressure.....	14.73 in.
Intake Hole Size.....	10 in.
Number of Cartridge Filters.....	2
Cartridge Filter Material.....	Spun Bond Polyester
Single Cartridge Filter Diameter.....	20 in.
Single Cartridge Filter Surface Area.....	130 sq. ft.
Single Cartridge Filter Capability.....	99.9% of 0.2–2 Micron Particles
Number of Collection Drums.....	2
Collection Drum Size.....	55 Gallons
Sound Level.....	84–85 dB

Bag Information

Number of Collection Bags.....	2
Collection Bag Material.....	Plastic
Collection Bag Capacity.....	4913.5 cu. ft.
Collection Bag Diameter.....	22-7/16 in.
Collection Bag Length.....	26-3/4 in.

Impeller Information

Impeller Type.....	Radial Fin
Impeller Size.....	18 in.

Construction

Cyclone Body.....	16 Gauge Steel
Stand.....	13 Gauge Steel
Impeller.....	8mm Thick Welded Steel
Collection Drum.....	16 Gauge Steel
Blower Housing.....	11 Gauge Steel

Other Specifications:

ISO Factory.....	ISO 9001
Country Of Origin.....	Taiwan
Warranty.....	1 Year
Serial Number Location.....	Data Label on Machine
Assembly Time.....	3 hours

Features:

- Ramped inlet maximizes dust flow into collection drums
- Steel collection drums with casters for easy dust disposal
- Remote controlled magnetic switch
- Class "F" motor
- Dual pleated filters with cleaning brushes to maximize air flow
- Standard equipment mufflers reduce noise level without reducing air flow





MACHINE DATA SHEET

Customer Service #: (570) 546-9663 • To Order Call: (800) 523-4777 • Fax #: (800) 438-5901

MODEL G0638 10 HP CYCLONE DUST COLLECTOR

Product Dimensions:

Weight646 lbs.
 Length/Width/Height76-3/4 x 59-7/8 x 139-3/8 in.
 Foot Print (Length/Width)..... 77 x 60 in.

Shipping Dimensions:

Box 1

Type Wood Crate
 Content..... Machine
 Weight.....812 lbs.
 Length/Width/Height..... 90-1/4 x 39 x 42-1/2 in.

Box 2

Type Cardboard
 Content..... Filter Assembly
 Weight.....46 lbs.
 Length/Width/Height..... 68 x 21-3/4 x 21-3/4 in.

Box 3

Type Cardboard
 Content..... Filter Assembly
 Weight.....46 lbs.
 Length/Width/Height..... 68 x 21-3/4 x 21-3/4 in.

Electrical:

Switch.....Magnetic with Thermal Overload Protector
 Switch Voltage220V
 Remote Control Provided..... Yes
 Recommended Circuit Size 40/20A
 PlugNo

Motors:

Type TEFC Induction (Class F)
 Horsepower 10 HP
 Voltage 220/440V
 Prewired 220V
 Phase Three
 Amps 30/15A
 Speed..... 3450 RPM
 Cycle 60 Hz
 Number Of Speeds 1
 Power Transfer Direct Drive
 Bearings Shielded and Lubricated



Main Specifications:

Maximum CFM @ 4.3" SP.....	4029 CFM
Maximum Static Pressure.....	16.8 in.
Intake Hole Size.....	12 in.
Number of Cartridge Filters.....	2
Cartridge Filter Material.....	Spun Bond Polyester
Single Cartridge Filter Diameter.....	20 in.
Single Cartridge Filter Surface Area.....	198 sq. ft.
Single Cartridge Filter Capability.....	99.9% of 0.2–2 Micron Particles
Number of Collection Drums.....	2
Collection Drum Size.....	55 Gallons
Sound Level.....	86–87 dB

Bag Information

Number of Collection Bags.....	2
Collection Bag Material.....	Plastic
Collection Bag Capacity.....	4913 cu. in.
Collection Bag Diameter.....	22-7/16 in.
Collection Bag Length.....	26-3/4 in.

Impeller Information

Impeller Type.....	Radial Fin
Impeller Size.....	18-1/2 in.

Construction

Cyclone Body.....	16 Gauge Steel
Stand.....	13 Gauge Steel
Impeller.....	8mm Thick Welded Steel
Collection Drum.....	16 Gauge Steel
Blower Housing.....	11 Gauge Steel

Other Specifications:

ISO Factory.....	ISO 9001
Country Of Origin.....	Taiwan
Warranty.....	1 Year
Serial Number Location.....	Data Label on Machine
Assembly Time.....	3 hours

Features:

- Ramped inlet maximizes dust flow into collection drums
- Steel collection drums with casters for easy dust disposal
- Remote controlled Star Delta switch
- Class "F" motor
- Dual pleated filters with cleaning brushes to maximize air flow
- Standard equipment mufflers reduce noise level without reducing air flow



Identification

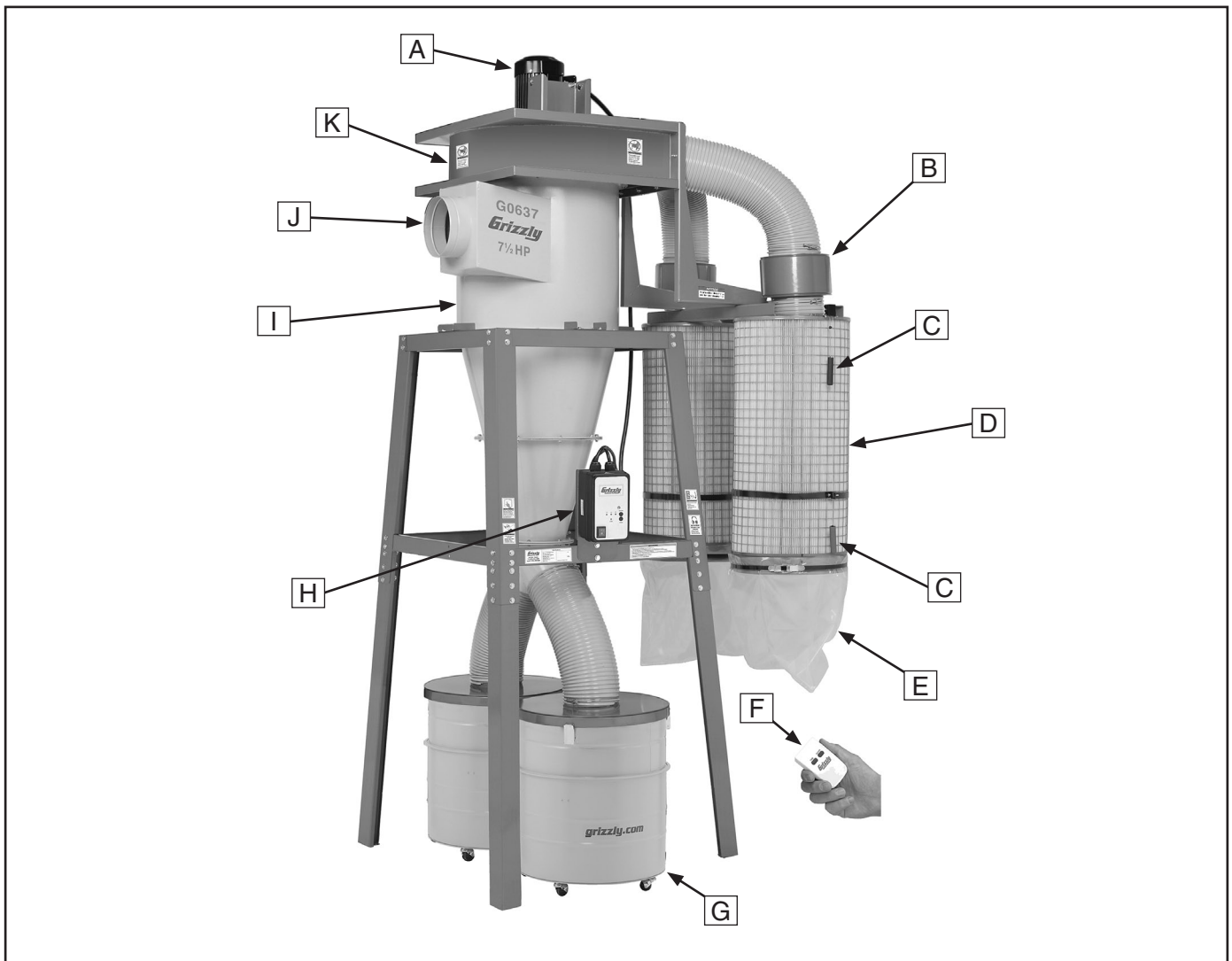

Figure 1. Identification (Model G0637 shown).

- A.** Motor
 - Model G0637: 7½ HP, 220/440V, 3-Phase
 - Model G0638: 10HP, 220/440V, 3-Phase
- B.** Noise Muffler
- C.** Canister Filter Brush Handles
- D.** Canister Filter
- E.** Collection Bag
- F.** Remote Control
- G.** Collection Drum
- H.** Control Box
- I.** Cyclone Assembly
- J.** Inlet Port
- K.** Blower Assembly



SECTION 1: SAFETY

WARNING

For Your Own Safety, Read Instruction Manual Before Operating this Machine

The purpose of safety symbols is to attract your attention to possible hazardous conditions. This manual uses a series of symbols and signal words intended to convey the level of importance of the safety messages. The progression of symbols is described below. Remember that safety messages by themselves do not eliminate danger and are not a substitute for proper accident prevention measures.



Indicates an imminently hazardous situation which, if not avoided, **WILL** result in death or serious injury.



Indicates a potentially hazardous situation which, if not avoided, **COULD** result in death or serious injury.



Indicates a potentially hazardous situation which, if not avoided, **MAY** result in minor or moderate injury. It may also be used to alert against unsafe practices.

NOTICE

This symbol is used to alert the user to useful information about proper operation of the machine.

WARNING

Safety Instructions for Machinery

- 1. READ THE ENTIRE MANUAL BEFORE STARTING MACHINERY.** Machinery presents serious injury hazards to untrained users.
- 2. ALWAYS USE ANSI APPROVED SAFETY GLASSES WHEN OPERATING MACHINERY.** Everyday eyeglasses only have impact resistant lenses—they are NOT safety glasses.
- 3. ALWAYS WEAR A NIOSH APPROVED RESPIRATOR WHEN OPERATING MACHINERY THAT PRODUCES DUST.** Wood dust can cause severe respiratory illnesses.
- 4. ALWAYS USE HEARING PROTECTION WHEN OPERATING MACHINERY.** Machinery noise can cause permanent hearing loss.
- 5. WEAR PROPER APPAREL. DO NOT** wear loose clothing, gloves, neckties, rings, or jewelry that can catch in moving parts. Wear protective hair covering to contain long hair and wear non-slip footwear.
- 6. NEVER OPERATE MACHINERY WHEN TIRED OR UNDER THE INFLUENCE OF DRUGS OR ALCOHOL.** Be mentally alert at all times when running machinery.



WARNING

Safety Instructions for Machinery

7. **ONLY ALLOW TRAINED AND PROPERLY SUPERVISED PERSONNEL TO OPERATE MACHINERY.** Make sure operation instructions are safe and clearly understood.
8. **KEEP CHILDREN AND VISITORS AWAY.** Keep all children and visitors a safe distance from the work area.
9. **MAKE WORKSHOP CHILDPROOF.** Use padlocks, master switches, and remove start switch keys.
10. **NEVER LEAVE WHEN MACHINE IS RUNNING.** Turn power **OFF** and allow all moving parts to come to a complete stop before leaving machine unattended.
11. **DO NOT USE IN DANGEROUS ENVIRONMENTS.** DO NOT use machinery in damp, wet locations, or where any flammable or noxious fumes may exist.
12. **KEEP WORK AREA CLEAN AND WELL LIGHTED.** Clutter and dark shadows may cause accidents.
13. **USE A GROUNDED EXTENSION CORD RATED FOR THE MACHINE AMPERAGE.** Grounded cords minimize shock hazards. Undersized cords create excessive heat. Always replace damaged extension cords.
14. **ALWAYS DISCONNECT FROM POWER SOURCE BEFORE SERVICING MACHINERY.** Make sure switch is in OFF position before reconnecting.
15. **MAINTAIN MACHINERY WITH CARE.** Keep blades sharp and clean for best and safest performance. Follow instructions for lubricating and changing accessories.
16. **MAKE SURE GUARDS ARE IN PLACE AND WORK CORRECTLY BEFORE USING MACHINERY.**
17. **REMOVE ADJUSTING KEYS AND WRENCHES.** Make a habit of checking for keys and adjusting wrenches before turning machinery **ON**.
18. **CHECK FOR DAMAGED PARTS BEFORE USING MACHINERY.** Check for binding or misaligned parts, broken parts, loose bolts, and any other conditions that may impair machine operation. Repair or replace damaged parts before operation.
19. **USE RECOMMENDED ACCESSORIES.** Refer to the instruction manual for recommended accessories. Improper accessories increase risk of injury.
20. **DO NOT FORCE MACHINERY.** Work at the speed for which the machine or accessory was designed.
21. **SECURE WORKPIECE.** Use clamps or a vise to hold the workpiece when practical. A secured workpiece protects your hands and frees both hands to operate the machine.
22. **DO NOT OVERREACH.** Maintain stability and balance at all times.
23. **MANY MACHINES CAN EJECT WORKPIECES TOWARD OPERATOR.** Know and avoid conditions that cause the workpiece to "kickback."
24. **ALWAYS LOCK MOBILE BASES (IF USED) BEFORE OPERATING MACHINERY.**
25. **CERTAIN DUST MAY BE HAZARDOUS** to the respiratory systems of people and animals, especially fine dust. Be aware of the type of dust you are exposed to and always wear a respirator designed to filter that type of dust.



WARNING

Additional Safety for Dust Collectors

- 1. MACHINE USE.** Do not use this dust collector to pick up liquids and metal scraps, including, but not limited to, nails and filings. Also, do not pick up material which cannot safely pass through the impeller such as solid wood scraps.
- 2. KEEPING FINGERS SAFE.** Do not place your hands or tools near the open inlet during operation. The moving impeller could cause serious damage to body parts if touched while spinning.
- 3. SAFE SERVICING.** Disconnect power and allow the impeller to come to a complete stop before servicing or working on the dust collector ducting system.
- 4. SUSPENDED DUST PARTICLES AND IGNITION SOURCES.** Do not operate the dust collector in areas where explosion risks would be high if dust were dispersed into the area. Areas of high risk include, but are not limited to, areas near pilot lights and/or open flames.
- 5. DUST HAZARD.** Be aware that certain woods may cause an allergic reaction in people and animals, especially when exposed to fine dust. Make sure you know what type of wood dust you will be exposed to in case of an allergic reaction. Always wear an approved respirator during and for a short time after machine operation!
- 6. AVOIDING FIRES.** Do not allow steel to strike against impeller—this may produce a spark. Sparks can smolder in wood dust for a long time before fire or flame is detected. If metal contacts metal during operation, immediately turn off the dust collector, flip the disconnect switch and wait for all moving parts to stop. Remove collection bags and empty the dust into an approved air tight metal container in case of spark. Remedy the metal to metal contact problem before resuming operation.
- 7. OPERATIONAL QUESTIONS.** If at any time you are experiencing difficulties performing the intended operation, stop using the machine! Then contact our Tech Support or ask a qualified expert how the operation should be performed.
- 8. CLEANING AIR.** Do not confuse this dust collector with an air cleaner. This dust collector is only designed to collect dust from a machine, not clean dust suspended in the air.
- 9. EMPTYING DUST.** When emptying dust from the collection bags or drum, wear a respirator and safety glasses. Empty dust into an approved container and dispose of properly.

WARNING

Like all machines there is danger associated with this dust collector. Accidents are frequently caused by lack of familiarity or failure to pay attention. Use this machine with respect and caution to lessen the possibility of operator injury. If normal safety precautions are overlooked or ignored, serious personal injury may occur.

CAUTION

No list of safety guidelines can be complete. Every shop environment is different. Always consider safety first, as it applies to your individual working conditions. Use this and other machinery with caution and respect. Failure to do so could result in serious personal injury, damage to equipment, or poor work results.



SECTION 2: CIRCUIT REQUIREMENTS

⚠️ WARNING

Serious personal injury could occur if you connect the machine to the power source before you have completed the set up process. **DO NOT** connect the machine to the power source until instructed to do so.

Full Load Amperage Draw

G0637 7½ HP 220V 3-Phase	25 Amps
G0637 7½ HP 440V 3-Phase	12.5 Amps
G0638 10 HP 220V 3-Phase.....	30 Amps
G0638 10 HP 440V 3-Phase.....	15 Amps

Circuit Requirements

We recommend connecting your machine to a dedicated and grounded circuit that is rated for the amperage given below. Never replace a circuit breaker on an existing circuit with one of higher amperage without consulting a qualified electrician to ensure compliance with wiring codes. **If you are unsure about the wiring codes in your area or you plan to connect your machine to a shared circuit, consult a qualified electrician.**

G0637 7½ HP 220V 3-Phase	40 Amp
G0637 7½ HP 440V 3-Phase	20 Amp
G0638 10 HP 220V 3-Phase.....	40 Amp
G0638 10 HP 440V 3-Phase.....	20 Amp

Connection to Power

Have a qualified electrician hardwire this machine to a dedicated locking shut-off switch (see **Figure 2**) that is connected to the main power source.

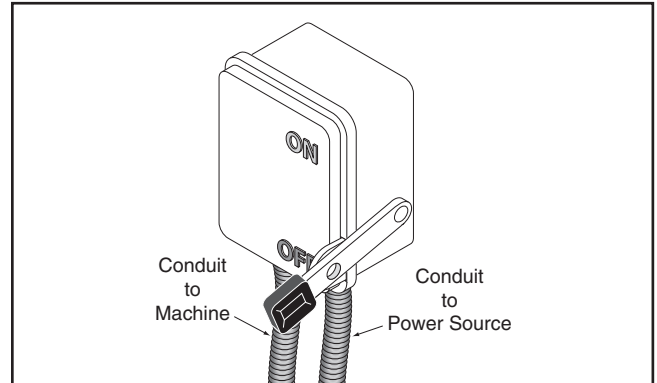

Figure 2. Hardwired locking disconnect switch.

	<h2>⚠️ WARNING</h2> <p>Electrocution or fire could result if this machine is not grounded correctly or if your electrical configuration does not comply with local and state codes. Ensure compliance by checking with a qualified electrician!</p>
--	---

Phase Converter

When using a phase converter, the power from the manufactured power leg (sometimes called the wild wire) can fluctuate. Connect the manufactured power leg to the **3L/2** terminal to prevent damage to the IC board or transformer. The wire from this terminal can handle some fluctuation because it goes directly to the motor. The power going to the **1L/2** and **5L/3** terminals goes to the IC board and transformer and must be consistent to prevent damage.



Model G0637 440V Conversion

The Model G0637 can be rewired for 440V operation. This rewiring job consists of disconnecting the dust collector from the power source, changing the control box, and rewiring the motor.

The necessary control box for this procedure can be purchased by calling our customer service number at (800) 523-4777 and ordering part number P0637119.

When complete, the rewiring job must be inspected by a qualified electrician before the dust collector is connected to the power source. Refer to the **Wiring Diagrams** on **Pages 45–46** for additional information.

Model G0638 440V Conversion

To operate the Model G0638 on 440V power, you must purchase a G0638 440V Conversion Kit. Call our customer service number at (800) 523-4777 and order part number P0638119.

To convert the G0638 to 440V:

1. DISCONNECT THE DUST COLLECTOR FROM THE POWER SOURCE!
2. Open the control box and identify the overload relay and the transformer (see **Figure 3**).

⚠WARNING

You must have a qualified electrician inspect your 440V rewiring job before connecting the dust collector to the power source. Failure to heed this warning may result in property damage, serious personal injury, or death from electrocution.

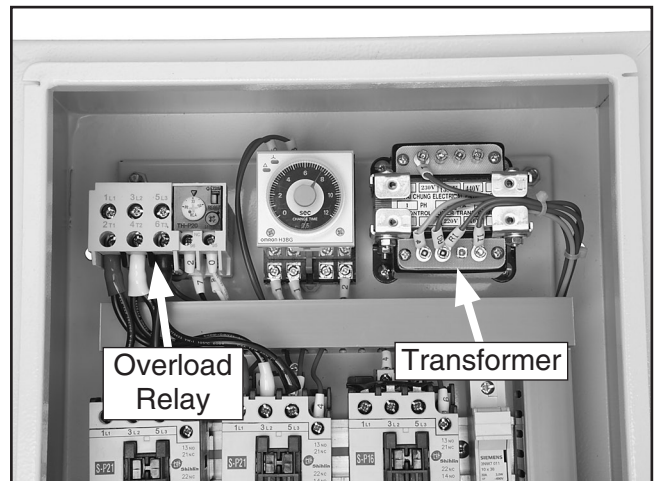

Figure 3. Model G0638 control box overload relay and transformer.

3. Replace the overload relay with the one included in the conversion kit, and turn the AMP dial to 15.
4. Move the "R0" wire on the transformer from the 220V terminal to the 440V terminal (see **Figure 4**).

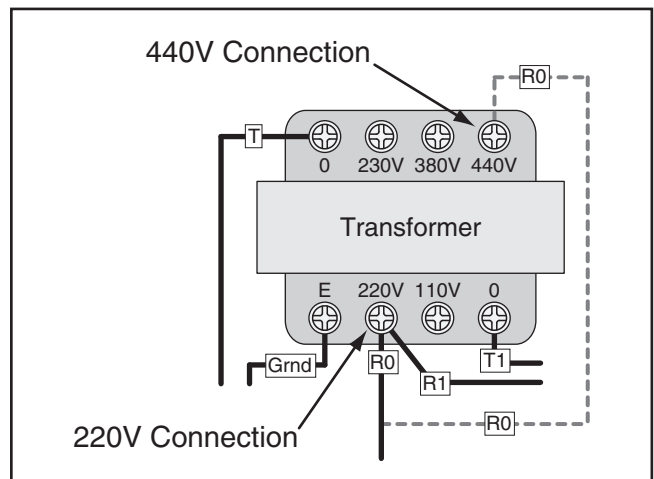

Figure 4. Model G0638 220V and 440V transformer connections.

5. Open the motor junction box and rewire the motor terminals for 440V power. Refer to **Wiring Diagram** on **Page 48** for additional information.



SECTION 3: SETUP

Setup Safety

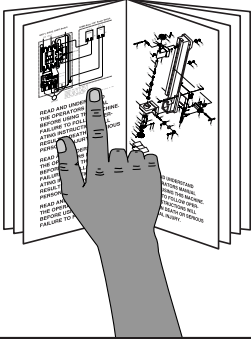

! WARNING
 This machine presents serious injury hazards to untrained users. Read through this entire manual to become familiar with the controls and operations before starting the machine!



! WARNING
 Wear safety glasses during the entire set up process!

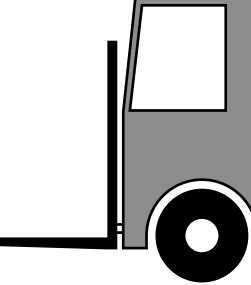

! WARNING
 The Model G0637/G0638 is a heavy machine. Serious personal injury may occur if safe moving methods are not used. To be safe, get assistance and use power equipment to move the shipping crate, remove the machine from the crate, and to assemble.

Items Needed for Setup

The following items are needed to complete the setup process, but are not included with your machine:

Description	Qty
• Assistance	As Needed
• Power Lifting Equipment	As Needed
• Safety Glasses	For Each Person
• Wrenches 1/2"	2
• Wrenches 3/8"	2
• Wrench 5/16"	1
• Wrench 10mm	1
• Phillips Head Screwdriver	1
• Level 3 ft. or more	1
• Floor Mounting Hardware	As Needed

Unpacking

To properly plan for and execute the setup process, read and understand all of the instructions contained in this **SETUP** section BEFORE assembling your dust collector.

The Model G0637/G0638 was carefully packed when it left our warehouse. If you discover the machine is damaged after you have signed for delivery, *please immediately call Customer Service at (570) 546-9663 for advice.*

Save the containers and all packing materials for possible inspection by the carrier or its agent. *Otherwise, filing a freight claim can be difficult.*

When you are completely satisfied with the condition of your shipment, inventory the contents.



Inventory

After all the parts have been removed from the boxes, you should have the following items:

Inventory: (Figures 5–8)	Qty
A. Upper Stand Braces	4
B. Upper Stand Legs	4
C. Filter Brace Supports (Long)	2
D. Control Box Bracket	1
E. Cyclone Mounting Brackets	4
F. Lower Stand Legs	4
G. Filter L-Braces	2
H. Filter Brace Support (Short)	1
I. Lower Stand Braces	4
J. Intake Cylinder	1
K. Outlet Port	1
L. Cyclone Funnel (Large).....	1
M. Intake Barrel.....	1
N. Cyclone Funnel (Small).....	1
O. Funnel Port.....	1
P. Blower Housing with Motor	1
Q. Control Box.....	1
R. Bag Holder Panels	8
S. Remote Control	1
T. Collection Drum Lid Latches	6
U. Casters 2".....	8
V. Collection Drum Lids	2
W. Upper Collection Drum Cylinders.....	2
X. Collection Drum Clamps	2
Y. Lower Collection Drum Cylinders.....	2
Z. Flexible Ducts 9" x 25½"	2
AA. Noise Mufflers	2
BB. Canister Filters	
—Model G0637 510 x 1200mm	2
—Model G0638 510 x 1500mm	2
CC. Flexible Ducts 8" x 31½"	2
DD. Flexible Ducts 8" x 4¾"	2
EE. Canister Filter Bag Clamps	2
FF. Gaskets (not shown):	
—Intake Cylinder 3 x 6 x 1800mm.....	1
—Outlet Port 3 x 6 x 1100mm	1
—Cyclone Funnel (Large)	
3 x 6 x 2500mm.....	1
—Intake Barrel 3 x 6 x 2500mm	1
—Cyclone Funnel (Small)	
3 x 6 x 2200mm.....	1
—Funnel Port 3 x 6 x 735mm	1
—Collection Drum Lids	
10 x 50 x 2000mm.....	2
GG. Rubber Mounting Gaskets (not shown):	
—Filter Canisters.....	4

Inventory (continued)	Qty
HH. Duct Clamps 8" (not shown)	8
II. Duct Clamps 9" (not shown)	4
JJ. Collection Bags (not shown):	
—Collection Drums 640 x 1200mm	10
—Canister Filters 510 x 600mm	2
KK. Hardware (not shown):	
—Hex Bolts ¼"-20 x ⅝".....	8
—Hex Bolts ⅜"-16 x ¾".....	72
—Hex Bolts ⅜"-16 x 1¼".....	8
—Hex Bolts ⅝"-18 x ¾".....	26
—Hex Bolts ⅝"-18 x 1".....	10
—Hex Bolts ⅝"-18 x 1¼".....	27
—Hex Bolts ⅝"-18 x 3".....	2
—Phillips Head Screws #10-24 x ⅜".....	72
—Fender Washers ⅝".....	8
—Flat Washers ¼".....	16
—Flat Washers ⅜".....	176
—Flat Washers ⅝".....	92
—Lock Washers ⅜".....	8
—Hex Nuts ¼"-20	8
—Hex Nuts ⅜"-16	16
—Hex Nuts ⅝"-18	37
—Hex Nuts #10-24.....	72
—Lock Nuts ⅜"-16	72
—G0638 (For Control Box Bracket)	
Phillips Head Screws M6-1 x 15.....	4
Flat Washers 6mm	4
Hex Nuts M6-1.....	4
LL. Rubber Handles (not shown)	
(For Bag Holders).....	4

NOTICE

Some hardware/fasteners and gaskets on the inventory list may arrive pre-installed. Check mounting locations before assuming that any items from the inventory list are missing.

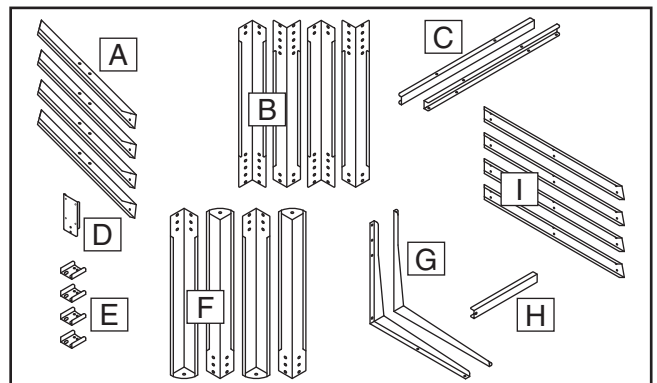

Figure 5. Model G0637/G0638 inventory A–I.



Site Considerations

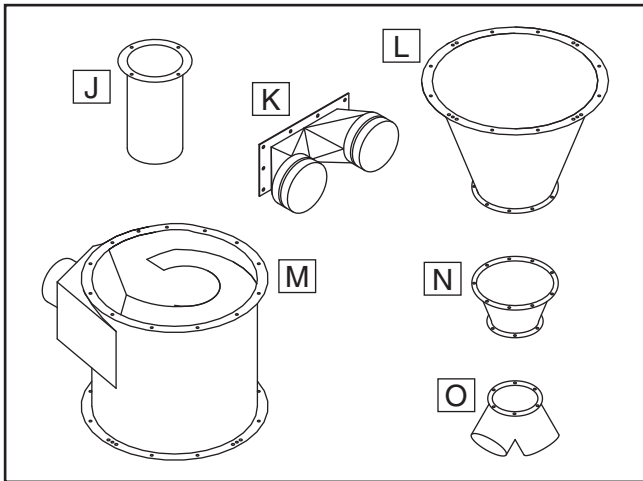

Figure 6. Model G0637/G0638 inventory J-O.

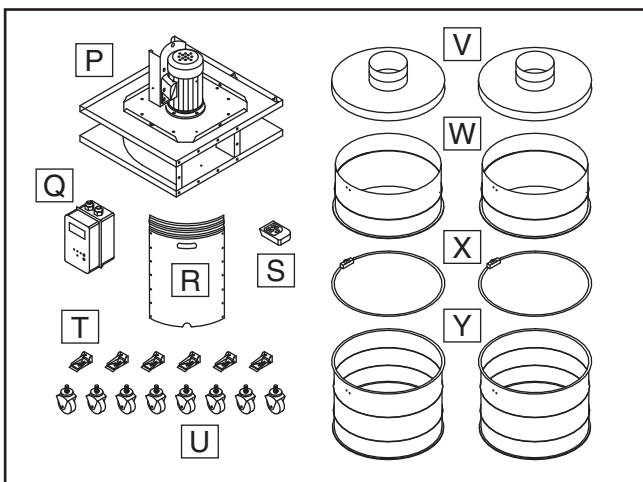

Figure 7. Model G0637/G0638 inventory P-Y.

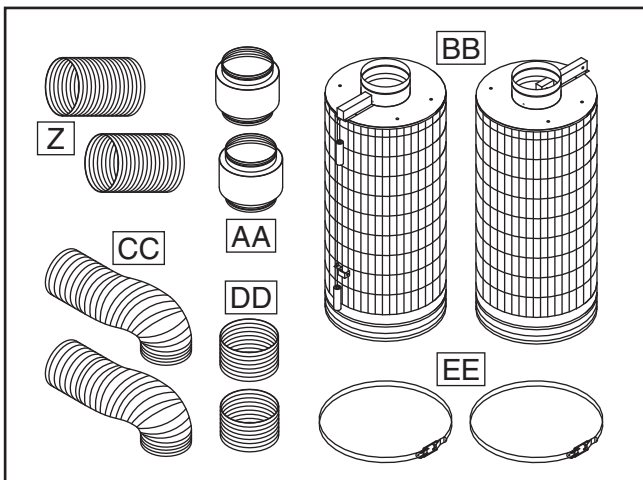

Figure 8. Model G0637/G0638 inventory Z-EE.

If any nonproprietary parts are missing (e.g. a nut or a washer), we will gladly replace them; or for the sake of expediency, replacements can be obtained at your local hardware store.

Floor Load

Refer to the **Machine Data Sheets** starting on **Page 3** for the weight, footprint, and height specifications of your machine. Some shop floors may require additional reinforcement to support the dust collection system.

Placement Location

Consider existing and anticipated needs, size of material to be processed through each machine, and space for auxiliary stands, work tables, other machinery, and the operator when establishing a location for your new machine. See **Figure 9** for the minimum clearance dimensions.

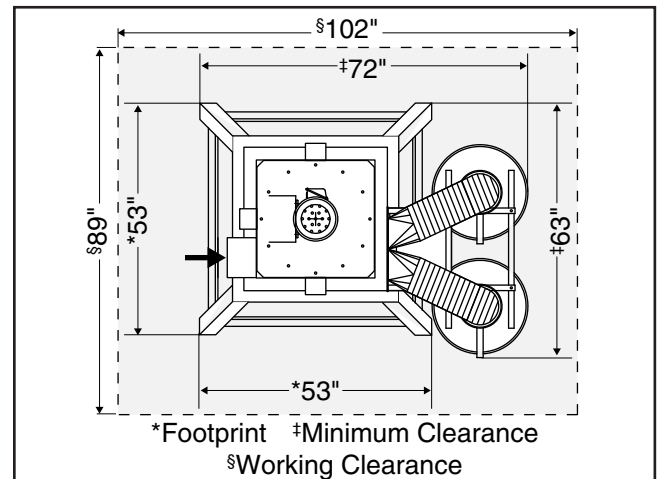

Figure 9. G0637/G0638 clearance dimensions.

Lighting

Lighting should be bright enough to eliminate shadow in the working zones of the machine and prevent eye strain. Follow local electrical codes for proper installation of new lighting.

	<p>⚠ CAUTION</p> <p>Children and visitors may be seriously injured if unsupervised. Lock all entrances to the shop when you are away. DO NOT allow unsupervised children or visitors in your shop at any time!</p>
--	--



Mounting to Shop Floor

We recommend that you mount your new dust collection system to the floor. Because floor materials may vary, floor mounting hardware is not included.

Bolting to Concrete Floors

Lag shield anchors with lag bolts and anchor studs (Figure 10) are two popular methods for anchoring an object to a concrete floor. We suggest you research the many options for mounting your machine and choose the one that best fits your specific application.

NOTICE

Anchor studs are stronger and more permanent alternatives to lag shield anchors; however, they will stick out of the floor, presenting a tripping hazard if you decide to move your machine.

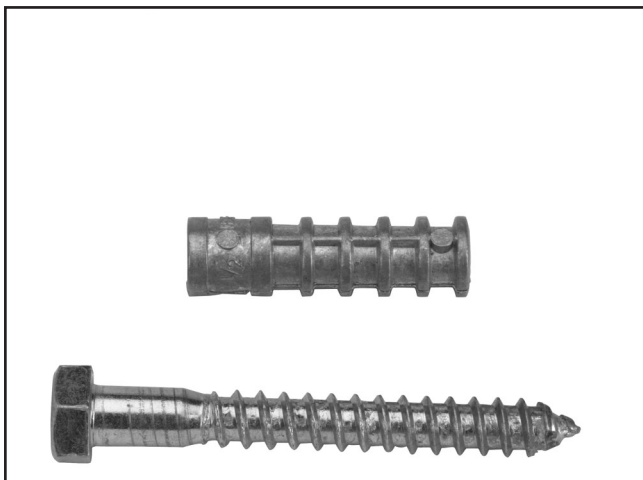

Figure 10. Typical fasteners for mounting to concrete floors.

NOTICE

Since your dust collection system will be hardwired to the power source, we strongly recommend securing your machine to the floor. Consult with your electrician to ensure compliance with applicable codes.

Clean Up

Some surfaces may be coated with a waxy oil to prevent corrosion during shipment. Remove this protective coating with a solvent cleaner or citrus-based degreaser such as Grizzly's G7895 Citrus Degreaser. To clean thoroughly, some parts must be removed. **For optimum performance from your machine, clean all moving parts or sliding contact surfaces.** Avoid chlorine-based solvents, such as acetone or brake parts cleaner that may damage painted surfaces. Always follow the manufacturer's instructions when using any type of cleaning product.

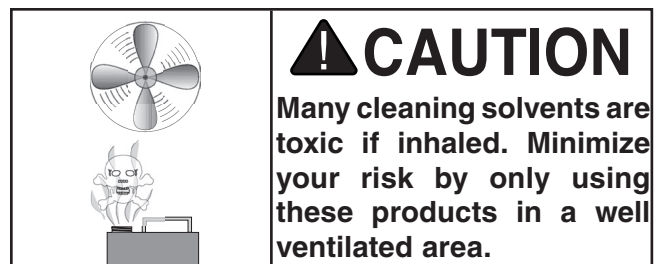
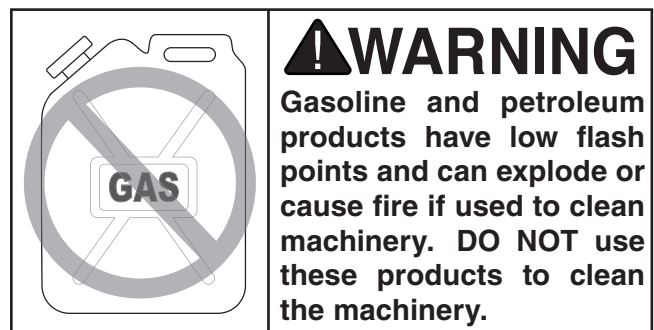

G7895—Grizzly Citrus Degreaser

This natural, citrus-based degreaser is a great solution for removing export grease, and it's much safer to work around than nasty solvents.



Figure 11. Grizzly citrus degreaser.



Hardware Identification Chart

USE THIS CHART TO MATCH UP HARDWARE DURING THE ASSEMBLY PROCESS.

MEASURE BOLT DIAMETER BY PLACING INSIDE CIRCLE

- #10
- 1/4"
- 5/16"
- 3/8"
- 7/16"
- 1/2"

- 4mm
- 6mm
- 8mm
- 10mm
- 12mm
- 16mm

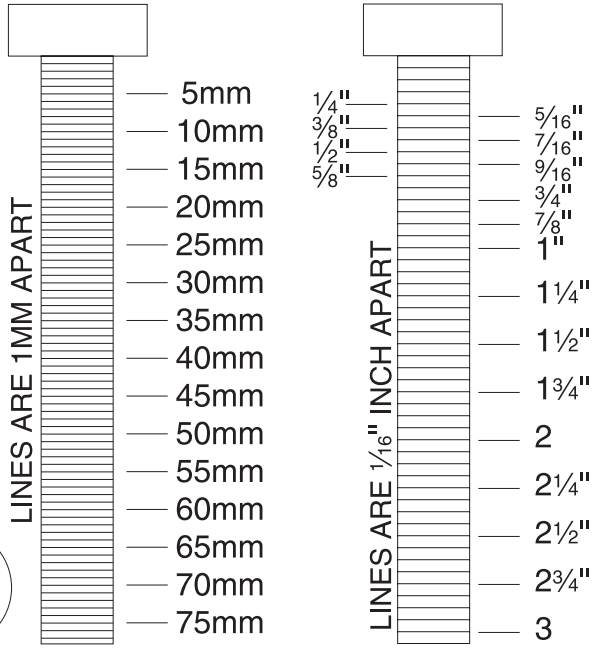
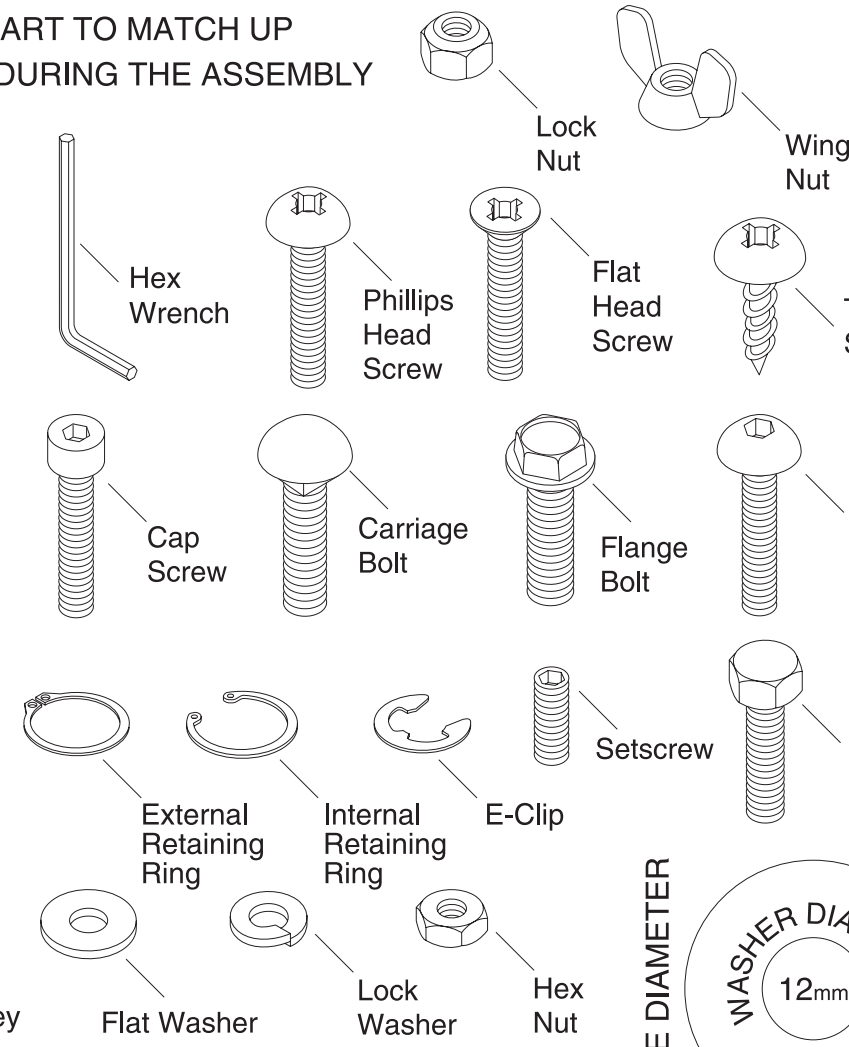

WASHERS ARE MEASURED BY THE INSIDE DIAMETER

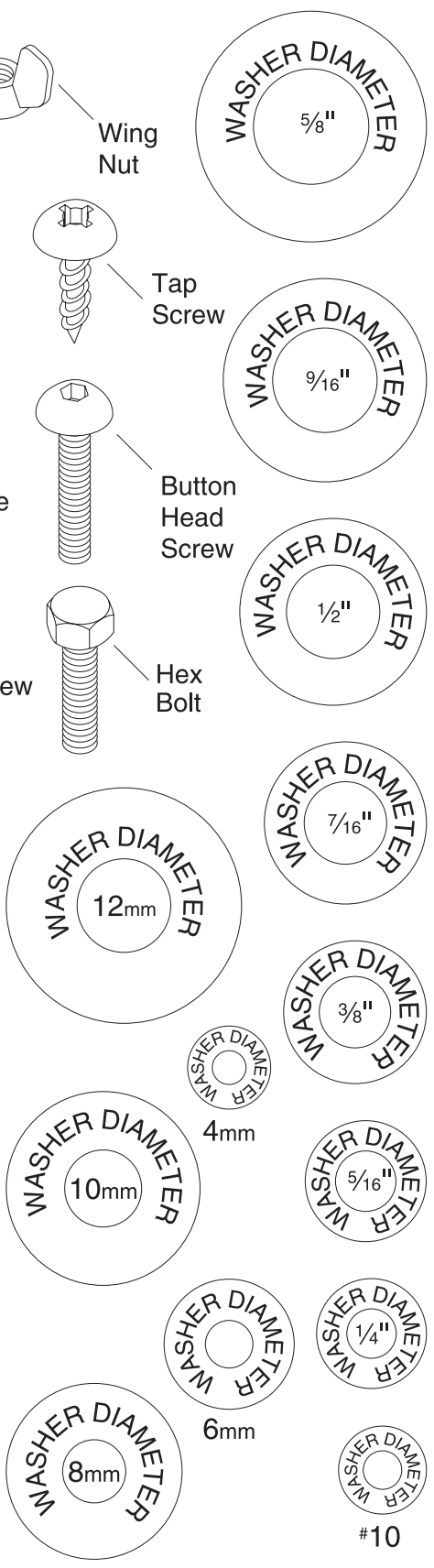

Assembly

Upper Stand

1. Use (8) $\frac{3}{8}$ "-16 x $\frac{3}{4}$ " hex bolts, (16) $\frac{3}{8}$ " flat washers, and (8) $\frac{3}{8}$ "-16 lock nuts to connect 2 upper stand legs, 1 upper stand brace, and 1 lower stand brace —*only finger tighten the fasteners* (see **Figure 12**).

Note: To make the installation of the fasteners easier, use scrap wood to raise the metal components off the floor.

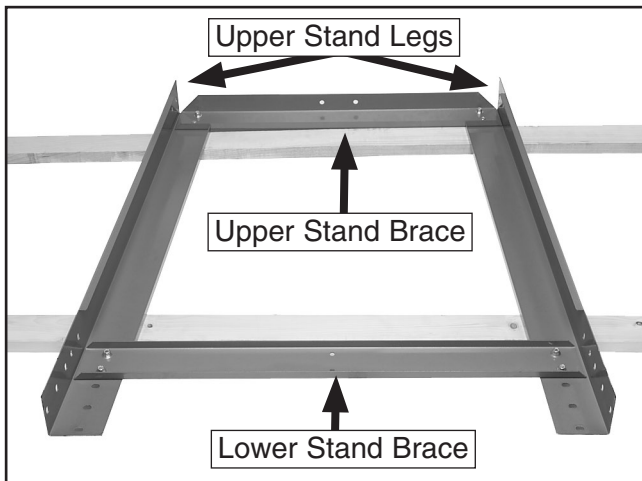

Figure 12. One side of upper stand assembled.

2. Repeat **Step 1** to make the other side of the upper stand.

Note: The $\frac{5}{16}$ " fender washers with a larger outside diameter will be used to attach the canister filters in later steps—do not use them for any other assembly.

3. Use (16) $\frac{3}{8}$ "-16 x $\frac{3}{4}$ " hex bolts, (32) $\frac{3}{8}$ " flat washer, and (16) $\frac{3}{8}$ "-16 lock nuts to connect the two sides of the upper stand with two upper stand braces and two lower stand braces—*only finger tighten the fasteners* (see **Figure 13**).



Figure 13. Upper stand assembled.

4. Place the level across a corner of the lower stand braces and move the upper stand around until that corner is level, then fully tighten all of the fasteners for that corner (see **Figure 14**).

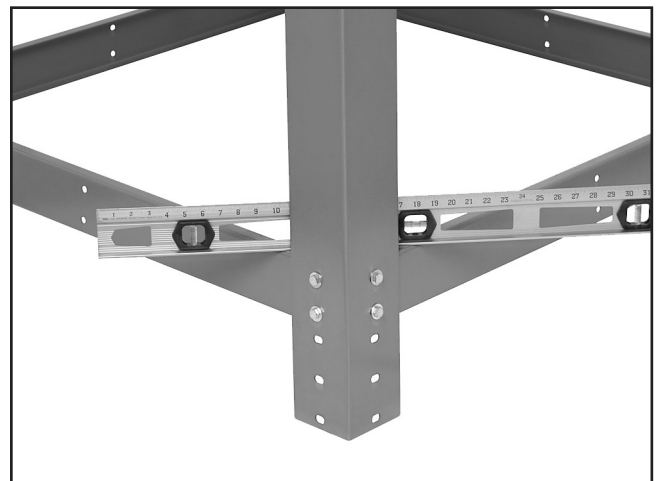

Figure 14. Level positioned on the upper stand.

5. Repeat **Step 4** for the rest of the corners, then set the upper stand assembly aside.



!WARNING

When using power lifting equipment during the assembly, make sure the equipment is safe, fully operational, and adequately rated for the weight being lifted. The operator of the equipment must be experienced and able to use safe methods during these processes. Failure to heed these warnings could result in serious personal injury or death.

Intake Cylinder and Blower Housing

1. Place the intake cylinder on the floor and apply the 3 x 6 x 1800mm gasket to the intake cylinder top rim, between the mounting holes and the inside edge (see **Figure 15**).

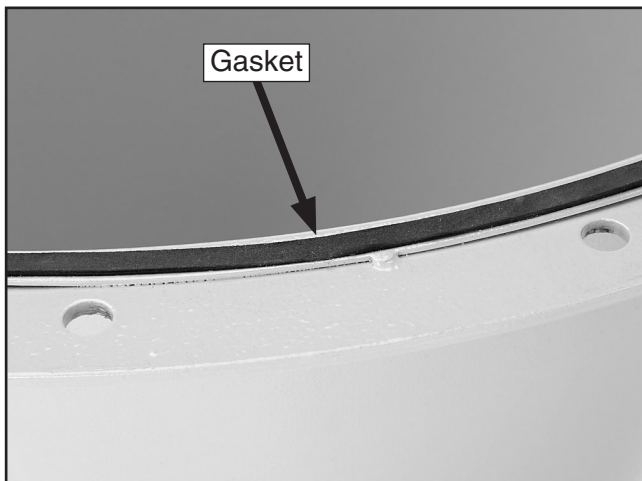

Figure 15. Gasket applied to the intake cylinder rim.

2. With assistance and the power lifting equipment, keep the intake cylinder on the floor and lower the blower housing over the top of the intake cylinder.

3. Use the (6) $\frac{5}{16}$ "-18 x $\frac{3}{4}$ " hex bolts and (6) $\frac{5}{16}$ " flat washers to secure the intake cylinder to the bottom of the blower housing (see **Figure 16**).

Note: Because the mounting bolts for the intake cylinder are not accessible after assembly is complete, consider using medium strength (red) Loctite® Threadlocker (Grizzly Model H2509 or H2515) to ensure the fasteners will not come loose with operational vibration.



Figure 16. Intake cylinder mounted to blower housing.

Intake Barrel and Large Cyclone Funnel

1. Position the large cyclone funnel so the small end rests on the floor.
2. Apply the 3 x 6 x 2500mm gasket to the top mating surface of the large cyclone funnel.
3. Take note that the large cyclone funnel top and the intake barrel mating surfaces have four places around the rims where there are three mounting holes close together.



- With assistance, place the intake barrel over the large cyclone funnel and align the mounting holes as illustrated in **Figure 17**.

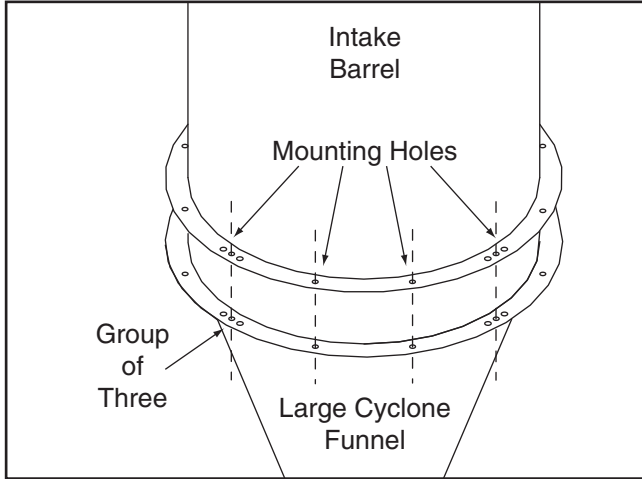

Figure 17. Intake barrel and large cyclone funnel mounting holes aligned.

NOTICE

When connecting parts that have a gasket applied to the mounting surface, always tighten the fasteners in a diagonal and rotational manner to ensure the gasket does not become crimped and compromise the seal.

- Connect the intake barrel and large cyclone funnel with (12) $\frac{5}{16}$ "-18 x $1\frac{1}{4}$ " hex bolts, (24) $\frac{5}{16}$ " flat washers, and (12) $\frac{5}{16}$ "-18 hex nuts in the mounting holes—excluding the left and right hole of the groups of three (see **Figure 18**).

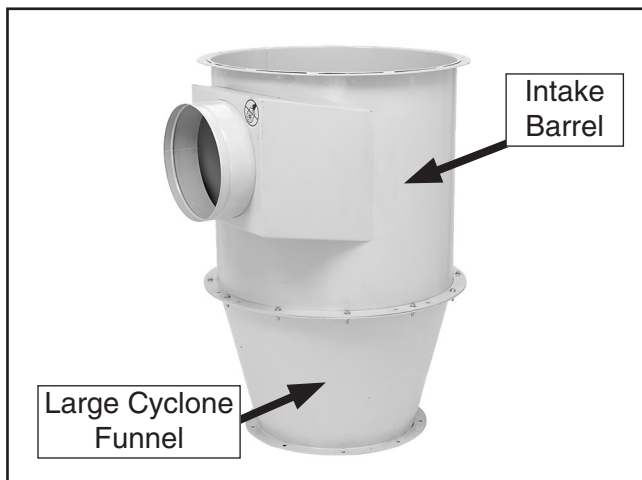

Figure 18. Intake barrel and large cyclone funnel.

- Install the four cyclone mounting brackets with (8) $\frac{3}{8}$ "-16 x $1\frac{1}{4}$ " hex bolts, (16) $\frac{3}{8}$ " flat washers, and (8) $\frac{3}{8}$ "-16 lock nuts (see **Figures 17 & 19**).



Figure 19. Cyclone mounting bracket mounted to collector assembly.

Blower Housing and Intake Barrel Assemblies

- Apply the 3 x 6 x 2500mm gasket to the top mating surface of the intake barrel assembly.
- Keeping the intake barrel assembly on the floor, lower the blower housing assembly over and approximately one inch away from the intake barrel assembly.
- Using two punches or Phillips screwdrivers as alignment guides (see **Figure 20**), lower the blower housing assembly onto the intake barrel assembly.

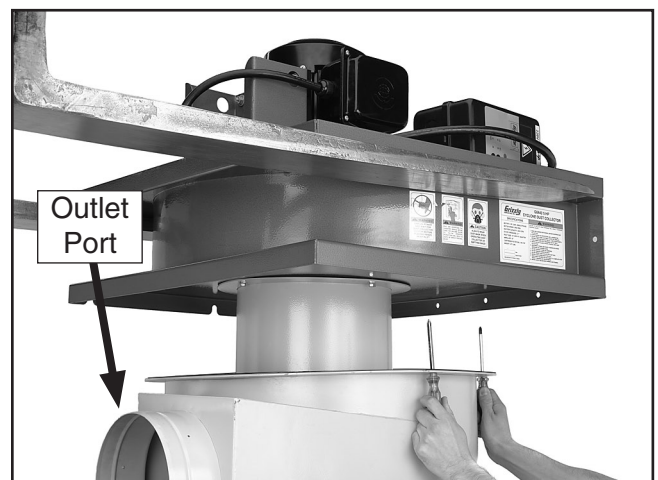

Figure 20. Aligning the mounting holes.



Note: Orient the two assemblies so that the large, round intake port of the intake barrel is NOT directly underneath the rectangular outlet port of the blower housing. The outlet port will connect to the canister filters and will not allow room for attachment of the intake ducting to the intake port.

4. Attach the two assemblies with the (12) $\frac{5}{16}$ "-18 x $\frac{3}{4}$ " hex bolts and (12) $\frac{5}{16}$ " flat washers (see **Figure 21**).



Figure 21. Securing intake barrel assembly to blower housing assembly.

Note: When installing the two bolts above the intake port of the intake barrel, use duct tape on the bottom of your wrench. This will hold the bolts in the wrench while inserting them in place (see **Figure 22**).

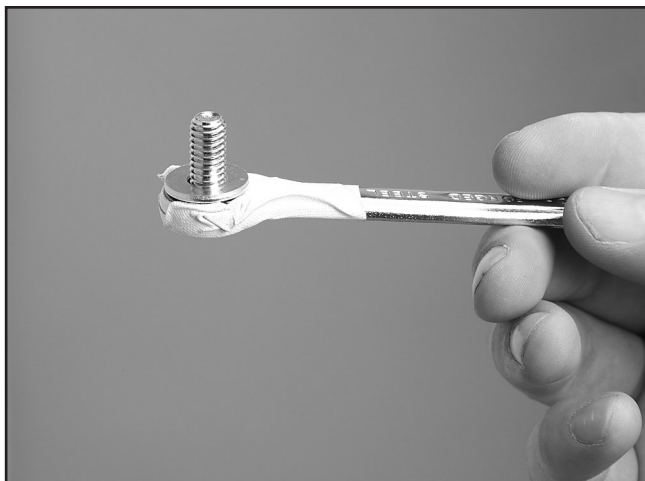

Figure 22. Using tape on a wrench in a tight spot.

Mount Blower/Intake Assembly to Upper Stand and Install Lower Stand Legs

1. Lower the blower/intake assembly into the upper stand assembly so that the cyclone mounting brackets align with the mounting holes of the upper stand braces (see **Figure 23**).

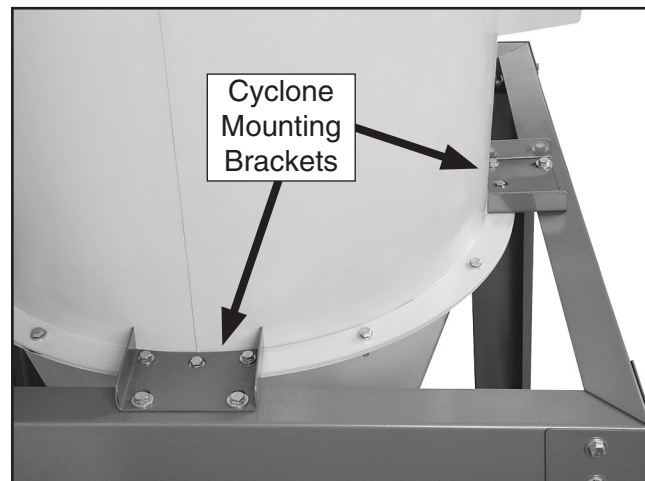

Figure 23. Mounting blower/intake assembly to upper stand.

2. Secure the mounting brackets to the upper stand with (8) $\frac{3}{8}$ "-16 x $\frac{3}{4}$ " hex bolts, (16) $\frac{3}{8}$ " flat washers, and (8) $\frac{3}{8}$ "-16 lock nuts.
3. With assistance and the power lifting equipment, raise the entire assembly high enough to install the lower stand legs.
4. Slide the four lower stand legs onto the bottoms of the upper stand legs—do NOT install the fasteners yet.
5. Slowly lower the weight of the assembly onto the lower stand legs.

Note: To keep the assembly stable while completing the next steps, keep the power lifting equipment engaged but not lifting.



- To allow the mounting holes of the lower stand legs to align properly, slightly loosen the 16 fasteners that connect the lower stand braces to the upper stand legs (see **Figure 24**).

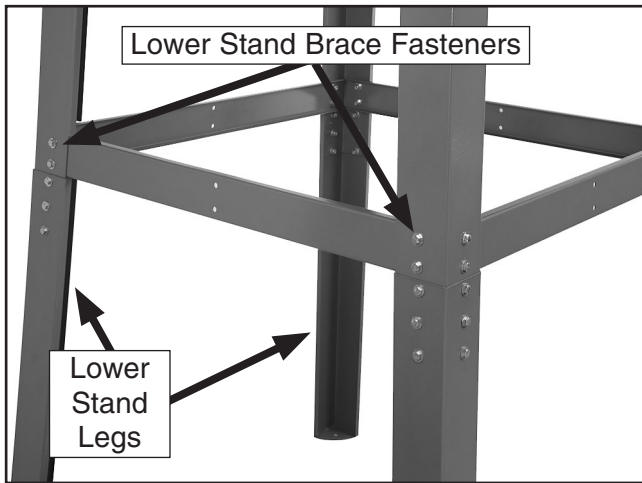

Figure 24. Lower stand legs attached to the upper stand assembly.

- Secure the lower stand legs to the upper stand assembly with (24) $\frac{3}{8}$ "-16 x $\frac{3}{4}$ " hex bolts, (48) $\frac{3}{8}$ " flat washers, and (24) $\frac{3}{8}$ "-16 lock nuts.
- Re-tighten the 16 fasteners connecting the lower stand braces to the assembly.
- Remove the power lifting equipment from the assembly.

Note: *The only other use for the power lifting equipment is moving the dust collection system into its permanent position when the assembly is complete.*

Outlet Port and Canister Filters

- Apply the 3 x 6 x 1100mm gasket to the square side of the outlet port.
- Mount the outlet port to the blower housing with (4) $\frac{5}{16}$ "-18 x 1" hex bolts, (8) $\frac{5}{16}$ " flat washers, and (4) $\frac{5}{16}$ "-18 hex nuts (see **Figure 25**).

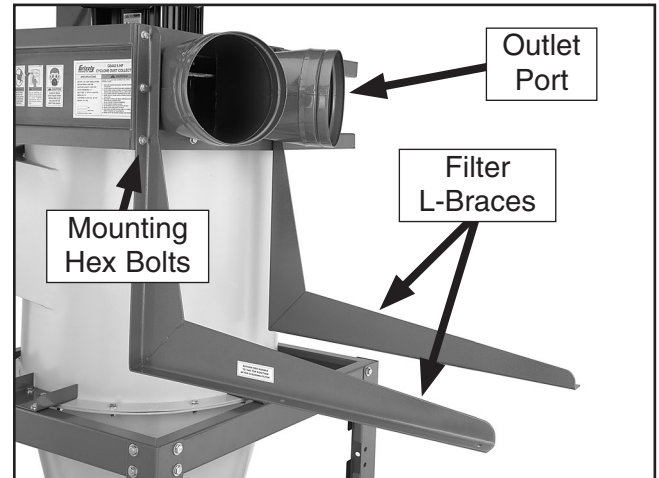

Figure 25. Filter L-braces mounted to blower housing.

- Attach the filter L-braces to either side of the outlet port on the blower housing with (6) $\frac{5}{16}$ "-18 x 1" hex bolts, (12) $\frac{5}{16}$ " flat washers, and (6) $\frac{5}{16}$ "-18 hex nuts.
- Secure the short filter brace support to the back of the filter L-braces with (2) $\frac{3}{8}$ "-16 x $\frac{3}{4}$ " hex bolts, (4) $\frac{3}{8}$ " flat washers, and (2) $\frac{3}{8}$ "-16 hex nuts (see **Figure 26**).

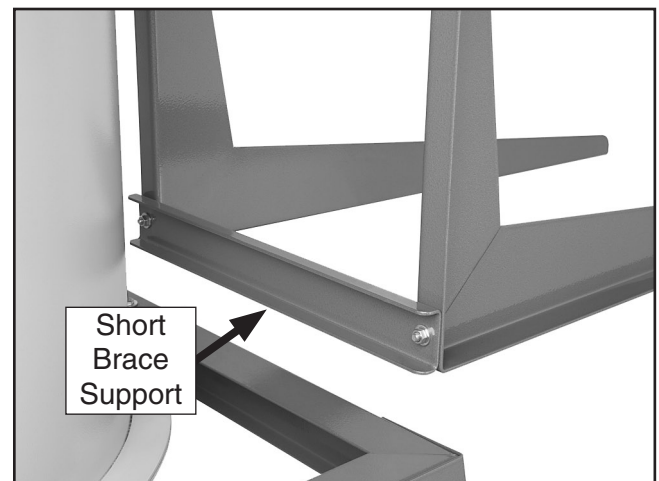

Figure 26. Short filter brace support attached.



- Attach the two long brace supports to the filter braces with (4) $\frac{3}{8}$ "-16 x $\frac{3}{4}$ " hex bolts, (8) $\frac{3}{8}$ " flat washers, and (4) $\frac{3}{8}$ "-16 hex nuts, as shown in **Figure 27**.



Figure 27. Long brace supports attached.

- With assistance, position the rubber mounting gaskets between the filter canisters and the long brace supports, and secure the canisters with (8) $\frac{5}{16}$ "-18 x $\frac{3}{4}$ " hex bolts and (8) $\frac{5}{16}$ " fender washers (see **Figure 28**).

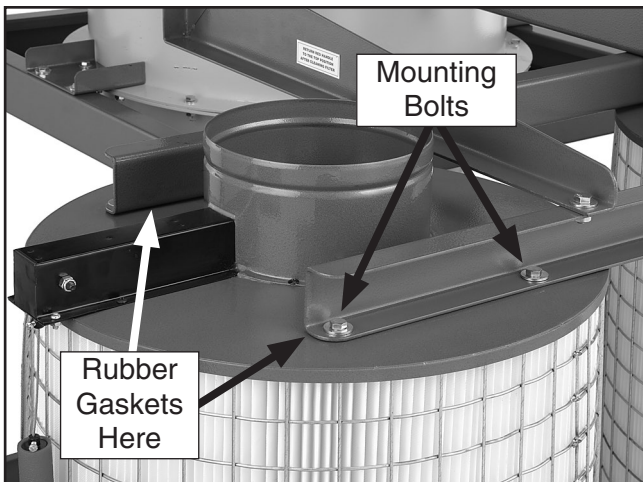

Figure 28. Canister filters mounted to the long support braces.

- Assemble the 8" x 31 $\frac{1}{2}$ " flexible ducts, the noise mufflers, and the 8" x 4 $\frac{3}{4}$ " flexible ducts with the 8" duct clamps (see **Figure 29**).

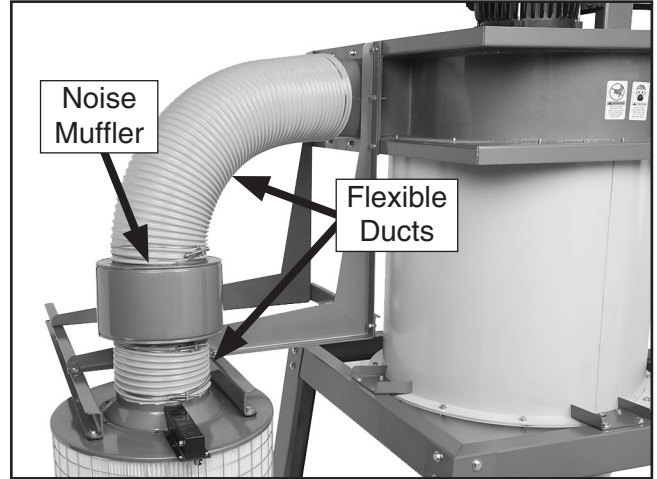

Figure 29. Ducting and noise muffler connected between blower housing and filter canister.

- Use the 8" duct clamps to connect the duct assemblies between the outlet port of the blower housing and the canister filters.
- Fit the plastic collection bags over the bottom of the filters and clamp in place with the metal bag clamps, as shown in **Figure 30**.



Figure 30. Canister filter collection bag installed.



Small Cyclone Funnel and Funnel Port

1. Apply the 3 x 6 x 2200mm gasket to the larger, top end of the small cyclone funnel, then place the cyclone funnel upside down on the floor.

Note: Use a clean covering on the floor to protect the gasket.

2. Apply the 3 x 6 x 735mm gasket to the top of the funnel port and place this upside down on top of the cyclone funnel.
3. Attach the small cyclone funnel and funnel port with (6) $\frac{5}{16}$ "-18 x $1\frac{1}{4}$ " hex bolts, (12) $\frac{5}{16}$ " flat washers, and (6) $\frac{5}{16}$ "-18 hex nuts.
4. With assistance, attach this assembly to the bottom of the large cyclone funnel with (9) $\frac{5}{16}$ "-18 x $1\frac{1}{4}$ " hex bolts, (18) $\frac{5}{16}$ " flat washers, and (9) $\frac{5}{16}$ "-18 hex nuts (see **Figure 31**).

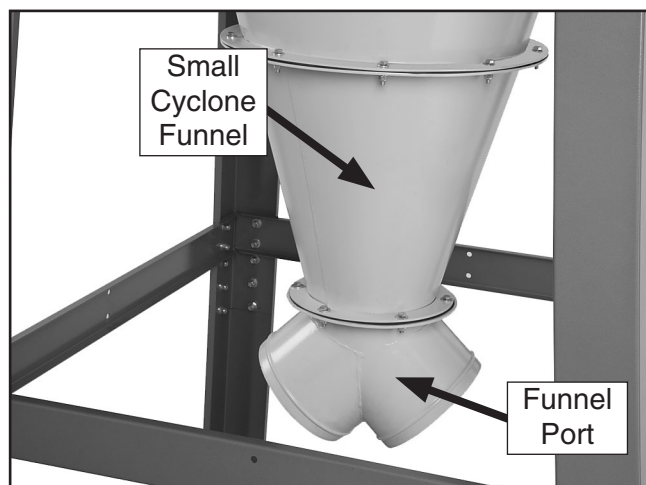

Figure 31. Small cyclone funnel and funnel port attached.

Dust Collection Drum Assemblies

1. For each lower collection drum cylinders, attach the casters to the bottom using (4) $\frac{3}{8}$ "-16 hex nuts, (4) $\frac{3}{8}$ " flat washers, and (4) $\frac{3}{8}$ " lock washers (see **Figure 32**).



Figure 32. Dust collection drum casters installed.

2. Connect each upper and lower collection drum cylinder with a collection drum clamp and use (1) $\frac{5}{16}$ "-18 x 3" hex bolt and (1) $\frac{5}{16}$ "-18 hex nut to tighten the clamp (see **Figure 33**).

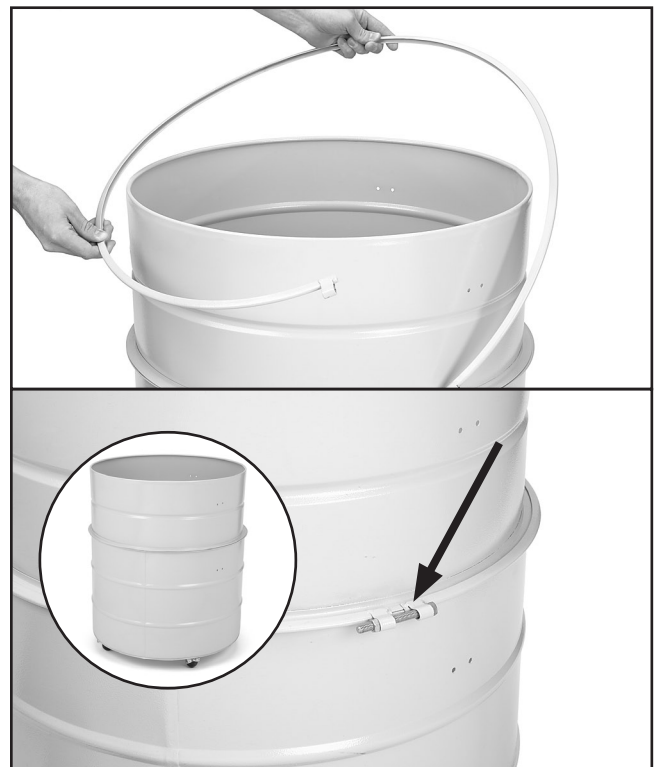

Figure 33. Installing drum clamp around dust collection cylinders.



3. Apply the 10 x 50 x 2000mm gaskets to the underside of the collection drum lids (see **Figure 34**).



Figure 34. Applying dust collection drum lid gasket.

4. Install the drum lid latches on the upper part of each collection drum assembly with (12) #10-24 x 3/8" Phillips head screws and (12) #10-24 hex nuts (see **Figure 35**).



Figure 35. Collection drum lid latch installed.

5. To prevent a vacuum leak in the collection drums, use (12) #10-24 x 3/8" Phillips head screws and (12) #10-24 hex nuts to plug the holes in the lower half of the collection drums.

6. Attach each set of four bag holder panels with the (24) #10-24 x 3/8" Phillips head screws and (24) #10-24 hex nuts to make two dust collection drum bag holders (see **Figure 36**).



Figure 36. Dust collection drum bag holder assembled.

7. Attach two rubber handles to the inside of each bag holder assembly with (4) 1/4"-20 x 5/8" hex bolts, (8) 1/4" flat washers, and (4) 1/4"-20 hex nuts.
8. Insert the 640 x 1200mm dust collection bags and bag holders into the drum collection assemblies, as shown in **Figure 37**.



Figure 37. Dust collection bag and bag holder inserted into collection drum assembly.



9. Secure the collection drum lids to the collection drums with the lid latches.
10. Connect the dust collection drum assemblies to the funnel port with the 9" flexible ducts and 9" duct clamps (see **Figure 38**).

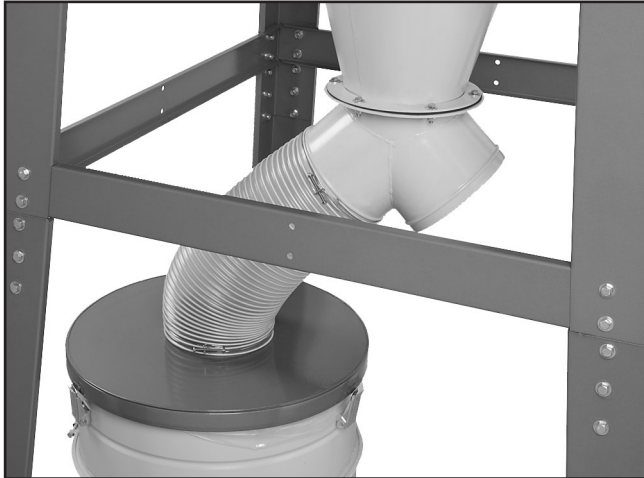

Figure 38. Dust collection drum assemblies connected to funnel port.

Model G0637 Control Box

1. Mount the control box onto the lower stand brace with (2) $\frac{3}{8}$ "-16 x $\frac{3}{4}$ " hex bolts, (4) $\frac{3}{8}$ " flat washers, and (2) $\frac{3}{8}$ "-16 hex nuts (see **Figure 39**).



Figure 39. Model G0637 control box mounted.

Note: The remote control uses IR (infrared) to communicate with the control box, and must have direct line-of-sight to the control box. Locate the control box with this in mind.

Model G0638 Control Box

1. Mount the control bracket onto the lower stand brace with (2) $\frac{3}{8}$ "-16 x $\frac{3}{4}$ " hex bolts, (4) $\frac{3}{8}$ " flat washers, and (2) $\frac{3}{8}$ "-16 hex nuts (see **Figure 40**).



Figure 40. Model G0638 control box bracket mounted.

2. Open the control box and identify the four mounting holes in the back of the cabinet.
3. Attach the control box to the bracket already mounted on the stand brace with (4) M6-1 x 15 Phillips head screws, (4) 6mm flat washers, and (4) M6-1 hex nuts (see **Figure 41**).



Figure 41. Model G0638 control box mounted.



Test Run

When the assembly is complete, test run your dust collection system to make sure it operates properly.

If, during the test run, you cannot easily locate the source of an unusual noise or vibration, stop using the machine immediately, then review the **Troubleshooting** on **Page 41**.

If you still cannot remedy a problem, contact our Tech Support at (570) 546-9663 for assistance.

To test run your dust collection system:

1. Make sure you have read the safety instructions at the beginning of the manual and that the machine is setup properly.
2. Make sure all tools and objects used during setup are cleared away from the machine.
3. Review **Circuit Requirements** on **Page 11** and connect the machine to the power source.
4. Flip the main power switch at the lower left hand corner of the control box (see **Figure 42**).

Note: For the Model G0638, make sure the **EMERGENCY STOP** button is popped out by twisting the knurled knob clockwise.

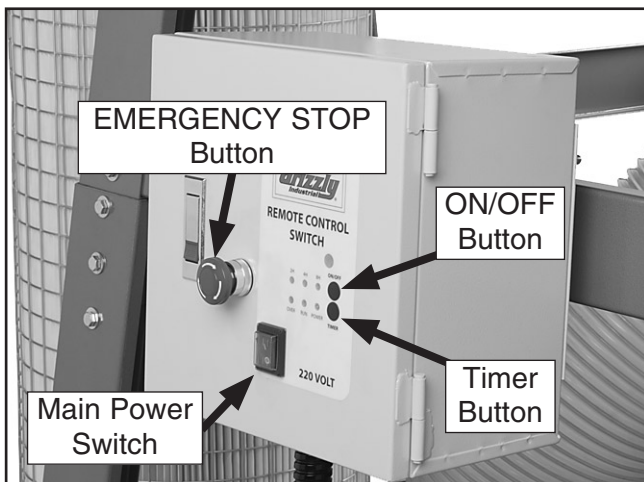

Figure 42. Control box (Model G0638 shown).

5. Press the ON/OFF button to turn the machine **ON**. Make sure your hand stays poised over the switch in case you need to quickly turn the machine **OFF**.
6. Listen to and watch for abnormal noises or actions. The machine should run smoothly with little or no vibration or rubbing noises.
 - If you suspect any problems, immediately turn the machine **OFF** and disconnect the machine from power. Refer to **Troubleshooting** on **Page 41** to identify and fix any problems.
 - If you cannot solve the problem with the use of the **Troubleshooting** guide, contact our Tech Support at (570) 546-9663 for assistance.
7. Press the TIMER button on the control box and cycle through each of the times to make sure the indicators light.
8. Press the TIMER button on the remote control and cycle through the times in the same manner as **Step 7**.
9. Toggle the ON/OFF button on both the control box and the remote control to make sure they are working properly.
10. **For the G0638 only:**
 - a. Turn the machine **OFF**.
 - b. Press the EMERGENCY STOP button in.
 - c. Turn the machine **ON**—nothing should happen.
 - d. Turn the machine **OFF**.
 - e. Pop the EMERGENCY STOP button out by twisting the knurled knob clockwise.
 - f. Pressing the ON/OFF button should now turn the dust collector **ON**.



SECTION 4: DESIGNING THE SYSTEM

General

The Model G0637/G0638 is designed to be a central dust collector system. Locate the dust collector in an out of the way location such as a corner or separate room. The large suction capacity of the Model G0637/G0638 allows great flexibility in planning and designing of your dust collection duct layout. Grizzly offers a complete line of dust collection accessories for setting up a stationary system. Additionally, Grizzly offers a complete guide book titled *Dust Collection Basics*.

Whatever system design you choose, always make sure there are no open flames (including pilot lights) in the same room as the dust collector; otherwise you risk an explosion if dust is dispersed into the air.

Duct Material

You have many choices regarding main line and branch line duct material. For best results, use metal duct for the main line and branch lines, then use a short lengths of flexible hose to connect each machine to the branch lines.

Plastic duct is also a popular material for home shops. However, be aware that there is a fire or explosion hazard if plastic duct material is used for dust collection without being grounded against static electrical charge build-up. This topic will be discussed later in this section. Another problem with using plastic is that it is less efficient per foot than metal.

Metal Duct

Advantages of metal duct is its conductivity and that it does not contribute to static electrical charge build-up. However, static charges are still produced when dust particles strike other dust particles as they move through the duct. Since metal duct is a conductor, it can be grounded quite easily to dissipate any static electrical charges.

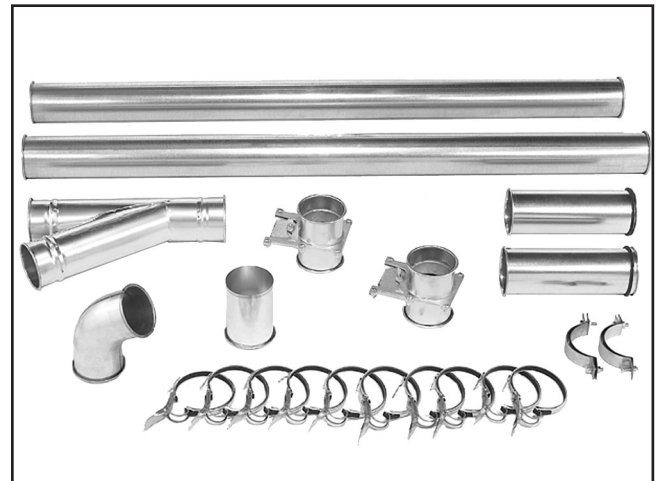

Figure 43. Examples of metal pipe and components.



There are quite a number of options when it comes to metal duct, but metal duct that is specially manufactured for dust collection is the best choice. When selecting your metal duct, choose high quality metal duct with smooth welded internal seams that will minimize airflow resistance. This type of duct usually connects to other ducts or elbows with a simple, self-sealing clamp, is very quick and easy to assemble, and can be readily dismantled and re-installed. This is especially important if you ever need to change things around in your shop or add more tools. See the **Accessories** section on **Page 36** for examples.

Avoid inferior metal duct that requires you to cut it to length and snap it together. This type of duct is time consuming to install because it requires you to seal all the seams with silicone and screw the components on the ends with sheet metal screws. Another disadvantage is the rough internal seams and crimped ends that unavoidably increase static pressure loss.

Flexible Duct

Flexible hose is generally used for short runs, small shops and at rigid duct-to-tool connections. There are many different types of flex hose on the market today. These are manufactured from materials such as polyethylene, PVC, cloth hose dipped in rubber and even metal, including steel and aluminum.

The superior choice for flexible ducting is metal flex hose that is designed to be flexible and as smooth as possible to reduce static pressure loss.

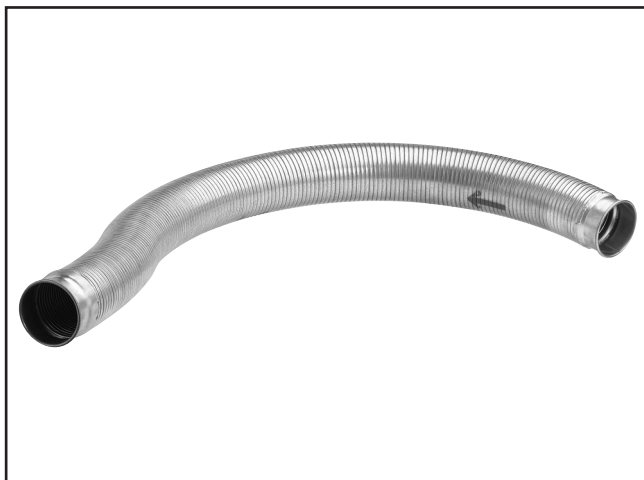

Figure 44. Example of flexible metal duct.

There are also many kinds of pure plastic flexible hose, such as non-perforated drainage type hose and dryer vent hose. Drainage type hose, while being economical, does not quite have the flexibility required for dust collection. The inside of the duct is also deeply corrugated and can increase the static pressure loss by as much as 50% over smooth wall duct. Dryer vent hose offers greater flexibility, but is non-resistant to abrasion and tends to collapse in a negative pressure system. We **DO NOT** recommend using dryer vent hose in your dust collection system.

If using flex-hose, choose one of the many types designed specifically for the movement of solid particles, i.e. dust, grains and plastics. However, the cost of specifically designed flexible duct can vary greatly. Grizzly offers polyethylene hose, which is well suited for the removal of particulate matter, especially sawdust, since it is durable and completely flexible. Polyethylene is also very economical and available in a wide variety of diameters and lengths for most applications.

Plastic Duct

The popularity of plastic duct is due to the fact that it is economical and readily available. It is also simple to assemble and easily sealed against air loss. The primary disadvantage of plastic duct for dust collection is the inherent danger of static electrical build-up.



Figure 45. Example of plastic duct and components.



System Design

Step 1. Decide Who Will Design

For most small-to-medium sized shops, you can design and build the dust collection system yourself without hiring engineers or consultants. We have included some basic information here to get you started on a dust collection system design.

If you have a large shop or must design a complicated system, then we recommend additional research beyond this manual, or seek help from an expert.

Step 2. Sketch Your Shop Layout

Planning is the most important step when designing a successful dust collection system.

Before you begin to draw your necessary layout sketch, we recommend that you visit our **FREE Workshop Planner** available on our website at www.grizzly.com.

Our *Workshop Planner* will allow you to quickly and easily draw and print a basic shop layout. Don't worry, non-Grizzly brand machines can be substituted with Grizzly machines for layout purposes. **Note:** After you're finished, make sure to save your layout for later modification.

Your sketch only needs the basic details of the shop layout, similar to **Figure 46**, including all your current/planned machines and your planned placement of the dust collector.

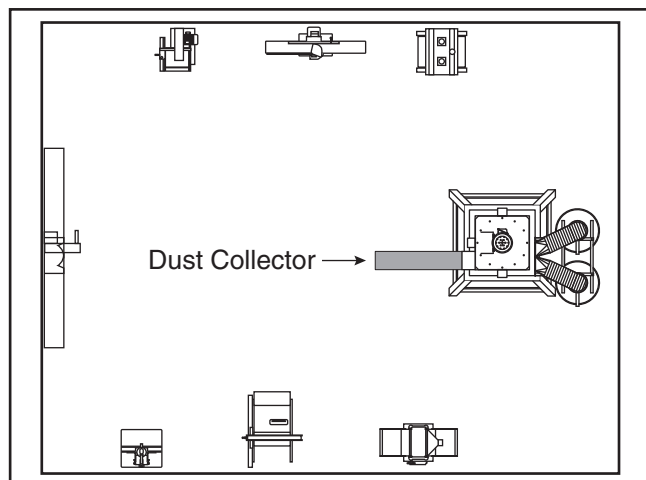

Figure 46. Initial sketch of shop layout.

Step 3. Sketch a Basic Duct Layout

For the next step, sketch how your machines will connect to the dust collector. Consider these general guidelines for planning an efficient system:

1. Machines that produce the most sawdust should be placed nearest to the dust collector (i.e. planers and sanders).
2. An ideal design will feature the shortest possible main line and secondary branch ducts. See **Figures 47 & 48** for ideas of good duct layouts vs bad duct layouts.

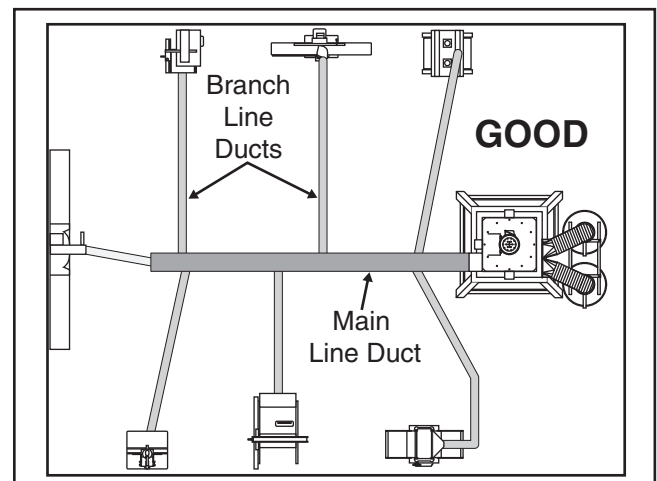

Figure 47. Good duct layout.

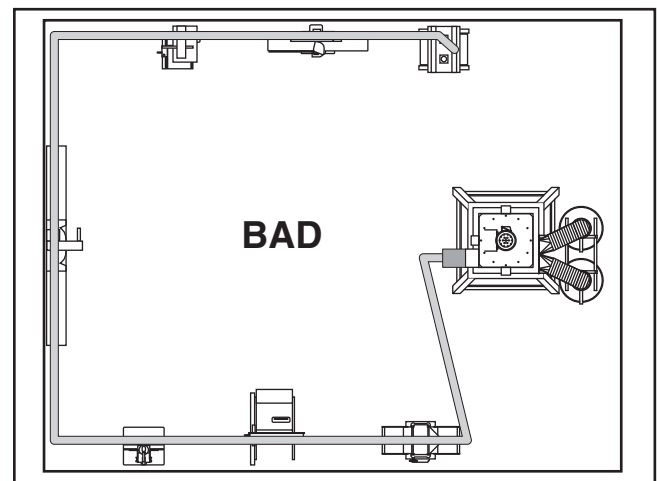

Figure 48. Bad duct layout.



3. Directional changes should be kept to a minimum. The more directional change fittings you use directly increases the overall resistance to airflow.
4. Gradual directional changes are more efficient than sudden directional changes (i.e. use the largest corner radius possible when changing hose or pipe direction).
5. Each branch line should have a blast gate immediately after the branch to control suction from one machine to another.
6. The simpler the system, the more efficient and less costly it will be.

Step 4. Determine Required CFM of Each Machine

Since each machine produces a different amount of sawdust, the requirements for the minimum amount of CFM needed to move that sawdust is unique to the machine (for example, a planer produces more sawdust than a table saw). Knowing this required CFM is important in gauging which size of duct to use.

Figure 49 will give you a close estimation of the airflow your machine requires. Machines that generate the most sawdust should be placed near the dust collector. If the machine has multiple dust ports, the total CFM required is the sum of all ports.

Machine Dust Port Size	Approximate Required CFM
2"	98
2.5"	150
3"	220
4"	395
5"	614
6"	884
7"	1203
8"	1570
9"	1990
10"	2456

Figure 49. Approximate required airflow for machines, based on dust port size.

If your machine does not have a built in dust port, use **Figure 50** to determine the size of dust port to install on your machine.

Machine	Average Dust Port Size
Table Saw	4"
Miter/Radial-Arm Saw	2"
Jointer (6" and smaller)	4"
Jointer (8"-12")	5"
Thickness Planer (13" and smaller)	4"
Thickness Planer (14"-20").....	6"
Shaper	4"
Router (mounted to table)	2"
Bandsaw.....	4"
Lathe.....	4"
Disc Sander (12" and smaller)	2"
Disc Sander (13-18").....	4"
Belt Sander (6" and smaller)	2"
Belt Sander (7"-9")	3"
Edge Sander (6" x 80" and smaller).....	4"
Edge Sander (6" x 80" and larger)	5"
Drum Sander (24" and smaller)	2 x 4"
Drum Sander (24" and larger).....	4 x 4"
Widebelt Sander (18" and smaller)	5"
Widebelt Sander (24"-37" single head) ..	2 x 6"
Widebelt Sander (24" _51" double head) ..	.5 x 4"

Figure 50. Dust port size and quantity per average machine.

Write the required CFM for each machine on your sketch, as shown in **Figure 51**.

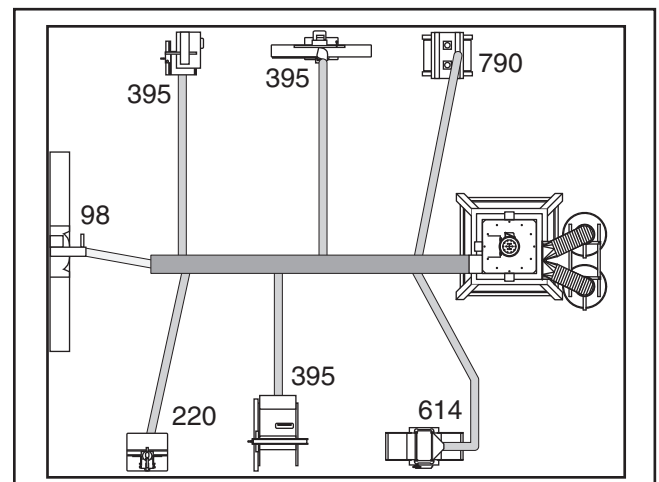

Figure 51. CFM requirements labeled for each machine.



Determining Main Line Duct Size

The general rule of thumb for a main line duct is that the *velocity* of the airflow must not fall below 3500 FPM.

For small/medium sized shops, using the inlet size of the dust collector as the main line duct size will usually keep the air velocity above 3500 FPM and, depending on your system, will allow you to keep multiple branches open at one time.

For the Model G0637/G0638 this is 10". Mark your drawing as in **Figure 52**.

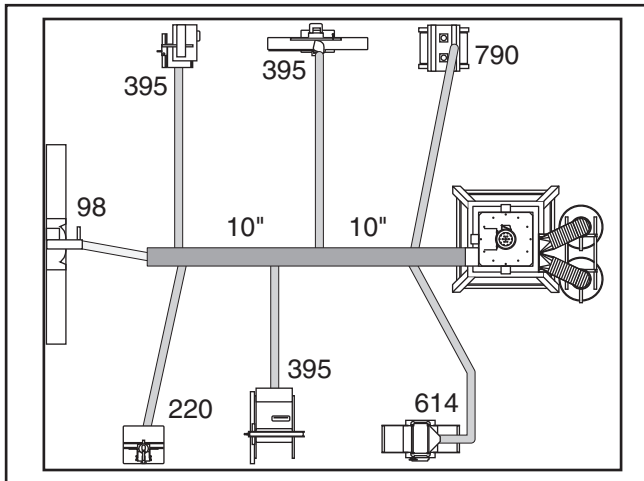

Figure 52. Main line size labeled on sketch.

Determining Branch Line Duct Size

The general rule of thumb for a branch line duct is that the *velocity* of the airflow must not fall below 4000 FPM.

For small/medium sized shops, using the dust port size from the machine as the branch line duct size will achieve the correct velocity in most applications. However, if the dust port on the machine is smaller than 4", make the branch line 4" and neck the line down right before the dust port.

Note: *Systems with powerful dust collectors work better if multiple blast gates are left open. This also allows you to run two machines at once. Experiment with different combinations of blast gates open/closed to find the best results for your system.*

Write your determined branch line sizes on your drawing, as shown in **Figure 53**.

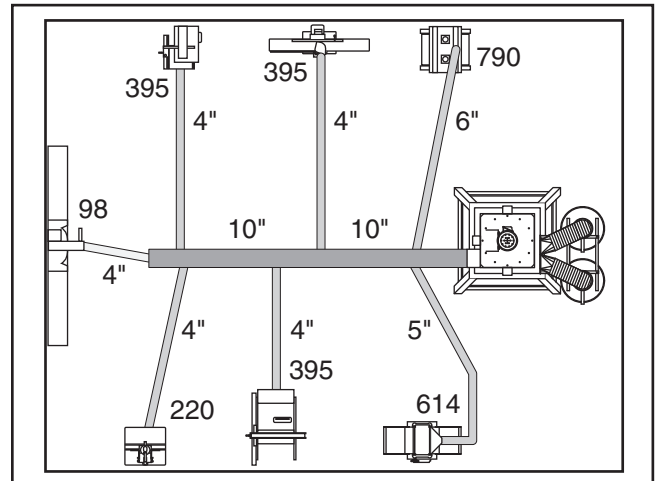

Figure 53. Branch line sizes labeled on sketch.

A few frequently asked questions when determining branch line sizes:

What size of branch line do I use if the machine has two dust ports?

Simply add the total CFM given for each size from **Figure 49** and refer to that CFM number in **Figure 54**. Then, split the branch line just before the dust ports with matching duct sizes.

How do I manage two machines on the same branch line?

You have two options:

1. If both machines will be running at the same time, add the total CFM given for each size from **Figure 49** and match the branch line given in **Figure 54**.
2. If both the machines will never be run at the same time, reference the machine with biggest dust port in **Figure 54** and add blast gates after the Y-branch to open/close the line to each machine.

Total CFM	Branch Line Size
600	5"
700	5"
800	6"
1000	6"
1200	7"
1400	8"
1600	8"

Figure 54. Branch line sizing chart by total CFM (for use when multiple machines share line).



Calculating Duct Resistance

Adding duct work, elbows, branches and any other components to a duct line increases airflow resistance (static pressure loss). This resistance can be minimized by using rigid (smooth) pipe and gradual curves, as opposed to flexible pipe and 90° elbows.

To help you think about this resistance, imagine riding a bicycle in a tunnel that is an exact replica of your duct work. If the inside of the tunnel is very bumpy (flexible pipe) and has many sharp turns (90° elbows), it will take a lot more effort for you to travel from one end to the other than if your path had been smooth and straight.

The purpose of calculating this resistance is to determine if it is low enough from the machine to the dust collector to meet the given requirement for the machine. Use the charts in **Figure 55** to calculate the resistance of duct work.

Duct Dia.	Approximate Static Pressure Loss Per Foot of Rigid Pipe		Approximate Static Pressure Loss Per Foot of Flex Pipe	
	Main Lines at 3500 FPM	Branch Lines at 4000 FPM	Main Lines at 3500 FPM	Branch Lines at 4000 FPM
2"	0.091	0.122	0.35	0.453
2.5"	0.08	0.107	0.306	0.397
3"	0.071	0.094	0.271	0.352
4"	0.057	0.075	0.215	0.28
5"	0.046	0.059	0.172	0.225
6"	0.037	0.047	0.136	0.18
7"	0.029	0.036	0.106	0.141
8"	0.023	0.027	0.08	0.108
9"	0.017	0.019	0.057	0.079

Fitting Dia.	90° Elbow	45° Elbow	45° Wye(Y)	90° Wye(Y)
3"	0.47	0.235	0.282	0.188
4"	0.45	0.225	0.375	0.225
5"	0.531	0.266	0.354	0.236
6"	0.564	0.282	0.329	0.235
7"	0.468	0.234	0.324	0.216
8"	0.405	0.203	0.297	0.189

Figure 55. Static pressure loss charts.

In most small/medium shops it is only necessary to calculate FPM for the line with the longest duct length or the most fittings (operating under the assumption that if the line with the highest resistance works, the others will be fine).

To calculate the static pressure loss of any given line in the system, follow these steps:

1. Make a list of each size duct in the line, including the length, and multiply those numbers by the static pressure loss value given in **Figure 55**.
2. List each type of elbow or branch and multiply the quantity (if more than one) by the static pressure loss given in **Figure 55**.
3. Add the additional factors from **Figure 56** to your list.

Additional Factors	Static Pressure Loss
Seasoned (well used) Dust Collection Filter	1
Entry Loss at Large Machine Hood	2

Figure 56. Additional factors affecting static pressure loss.

4. Total your list as shown in the example in **Figure 57** to come up with your overall static pressure loss number for that line.

Note: Always account for a seasoned filter, so you don't end up with a system that only works right when the filter is clean.

Main Line	
6" Rigid Pipe (.037) at 20'	.740
Branch Line	
4" Rigid Pipe (.075) at 10'	.750
4" Flex Pipe (.28) at 5'	1.400
Elbows/Branches	
6" 45° Y-Branch	.329
4" 45° Elbow	.225
Additional Factors	
Seasoned Filter	1.000
Total Static Pressure	4.444

Figure 57. Example list for totaling SP loss.



Note: *When calculating static pressure loss to determine if multiple lines can be left open at the same time, only include the main line numbers once.*

5. Compare the total static pressure loss for that line to the maximum static pressure rating of your dust collector (refer to the **Machine Data Sheets** on **Pages 3 & 5**).

—If your static pressure loss is below the static pressure rating of the dust collector, then the line will most likely be successful. Congratulations! You've just designed your own dust system. Refer to the **Accessories** section on **Page 36** to start buying the components necessary to make your system a reality.

—If your static pressure loss is equal to or above the static pressure rating of the dust collector, then that line will not effectively collect the dust. You must then modify some of the factors in that line to reduce the static pressure loss. Some of the ways to do this include 1) installing larger duct, 2) reducing amount of flexible duct used, 3) increasing machine dust port size, 4) moving machine closer to dust collector to eliminate duct length, and 5) reducing 90° elbows or replacing them with 45° elbows.

System Grounding

Since plastic hose is abundant, relatively inexpensive, easily assembled and air tight, it is a very popular material for conveying dust from woodworking machines to the dust collector. We recommend using flexible hose (flex-hose) to connect the woodworking machine to the dust collection system. However, plastic flex-hose and plastic duct are insulators, and dust particles moving against the walls of the plastic duct create static electrical build up. This charge will build until it discharges to a ground. If a grounding medium is not available to prevent static electrical build up, the electrical charge will arc to the nearest grounded source. This electrical discharge may cause an explosion and subsequent fire inside the system.

To protect against static electrical build up inside a non-conducting duct, a bare copper wire should be placed inside the duct along its length and grounded to the dust collector. You must also confirm that the dust collector is continuously grounded through the electrical circuit to the electric service panel.

If you connect the dust collector to more than one machine by way of a non-conducting branching duct system and blast gates, the system must still be grounded as mentioned above. We recommend inserting a continuous bare copper ground wire inside the entire duct system and attaching the wire to each grounded woodworking machine and dust collector.

Be sure that you extend the bare copper wire down all branches of the system. Do not forget to connect the wires to each other with wire nuts when two branches meet at a “Y” or “T” connection.



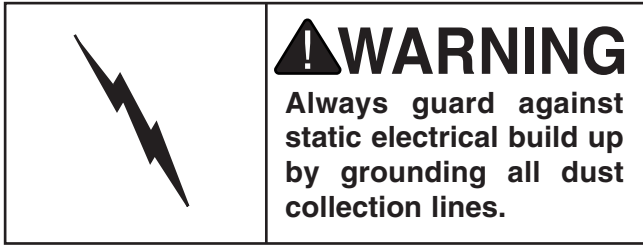

Ensure that the entire system is grounded. If using plastic blast gates to direct air flow, the grounding wire must be jumped (**Figure 58**) around the blast gate without interruption to the grounding system.

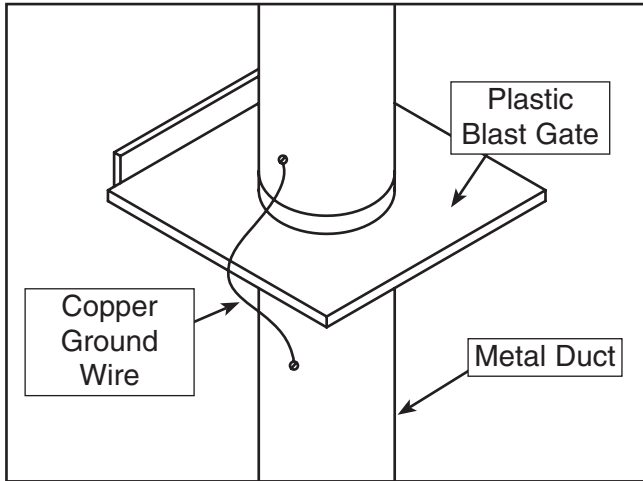

Figure 58. Ground jumper wire when using plastic blast gates and metal duct.

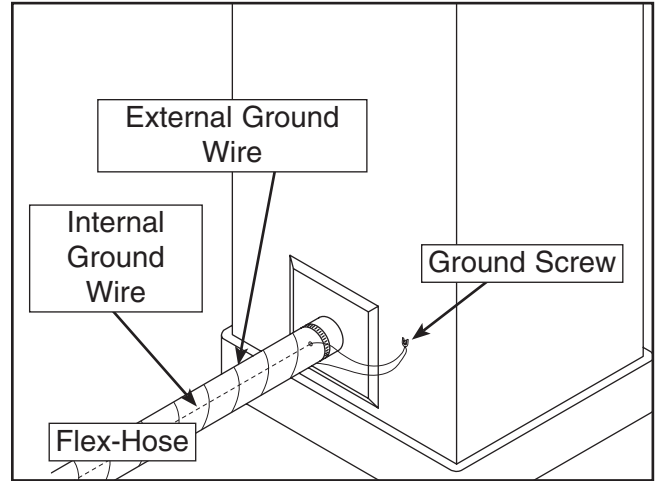

Figure 59. Flex-hose grounded to machine.

We also recommend wrapping the outside of all plastic ducts with bare copper wire to ground the outside of the system against static electrical build up. Wire connections at Y's and T's should be made with wire nuts.

Attach the bare ground wire to each stationary woodworking machine and attach to the dust collector frame with a ground screw as shown in **Figure 59**. Ensure that each machine is continuously grounded to the grounding terminal in your electric service panel.



SECTION 5: ACCESSORIES

H5293—4" Metal Duct Starter Kit

H5295—5" Metal Duct Starter Kit

H5297—6" Metal Duct Starter Kit

Save over 20% with this great starter kit. Includes: (2) machine adapters, (10) pipe clamps, (3) 5' straight pipes, (1) branch, (3) pipe hangers, (1) end cap, (3) adjustable nipples, (1) 90° elbow, and (1) 60° elbow.

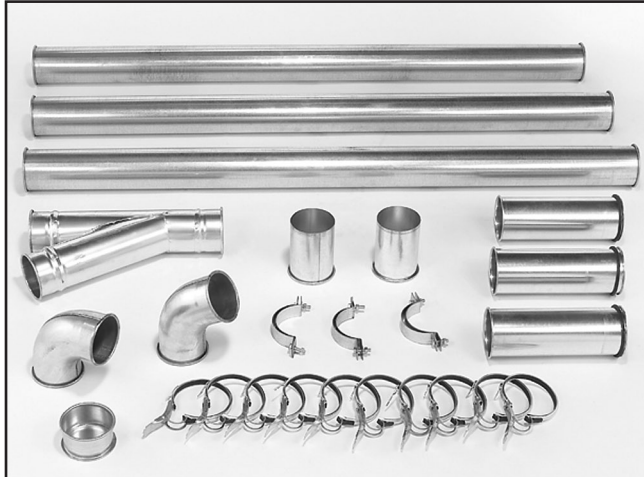

Figure 60. Metal Duct Starter Kit.

H5294—4" Metal Duct Machine Addition Kit

H5296—5" Metal Duct Machine Addition Kit

H5298—6" Metal Duct Machine Addition Kit

Save over 20% with this great machine addition kit. Includes: (2) blast gates, (1) machine adapter, (10) pipe clamps, (2) pipe hangers, (2) 5' straight pipes, (2) adjustable nipples, (1) branch, and (1) 60° elbow.

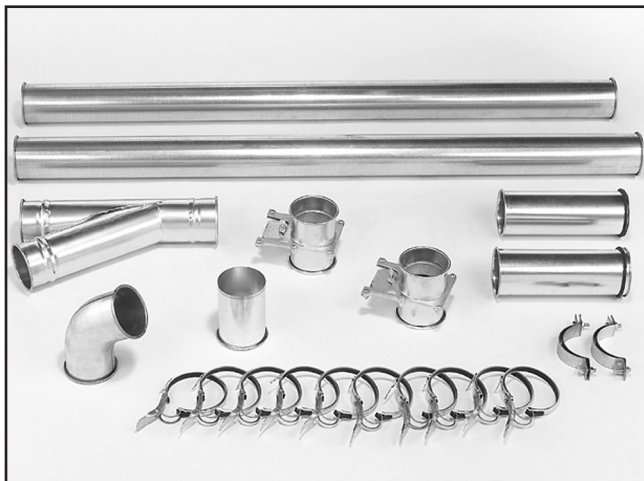

Figure 61. Metal Duct Machine Addition Kit.

G6162—4" x 5' Straight Metal Pipe

G7346—5" x 5' Straight Metal Pipe

G7364—6" x 5' Straight Metal Pipe

H5227—7" x 5' Straight Metal Pipe

H5237—8" x 5' Straight Metal Pipe

H5252—9" x 5' Straight Metal Pipe

These laser welded straight pipes ensure a super smooth internal seam. Ends easily clamp together for a sealed fit without screws or silicone.



Figure 62. Straight Metal Pipe.

H7216—5" x 5' Rigid Metal Flex Hose

H7217—6" x 5' Rigid Metal Flex Hose

H7218—7" x 5' Rigid Metal Flex Hose

H7219—8" x 5' Rigid Metal Flex Hose

H7220—9" x 5' Rigid Metal Flex Hose

This flex hose provides just enough flexibility to make difficult connections while still keeping the inside wall as smooth as possible to minimize static pressure loss.

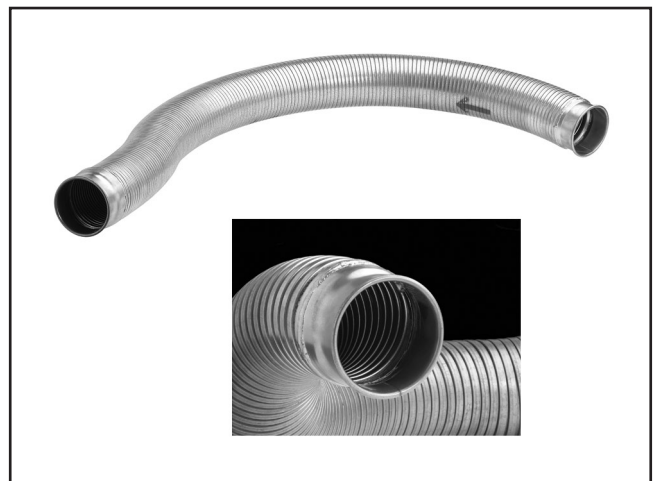

Figure 63. Rigid Metal Flex Hose.



Metal Elbows

These industrial metal elbows are available from 4"–8" with 90°, 60°, 45°, or 30° curves. Also, available with a 90° long radius curve. Call (800) 523-4777 or visit www.grizzly.com for more information and pricing.

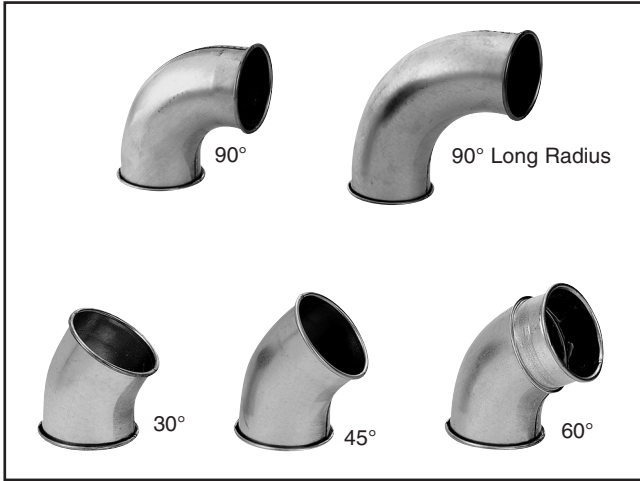

Figure 64. Metal elbow examples.

- G6177—4" Metal Blast Gate
- G7340—5" Metal Blast Gate
- G7358—6" Metal Blast Gate
- H5234—7" Metal Blast Gate
- H5249—8" Metal Blast Gate
- H5259—9" Metal Blast Gate



Figure 65. Metal Blast Gate.

Call 1-800-523-4777 To Order

Metal Branches

We carry many different branches, all designed to minimize airflow resistance.



Figure 66. Metal Branches.

Reducers & Adapters

We carry a multitude of reducers and elbows to cover most applications from 4" through 9".



Figure 67. Metal Reducers & Adapters.

- G6252—4" Floor Sweep
- G7341—5" Floor Sweep
- G7342—6" Floor Sweep

Great for cleaning up around the shop, these metal floor sweeps close tight when not in use.



Figure 68. Industrial Floor Sweep.



- G6163—4" Clamp**
- G7343—5" Clamp**
- G7361—6" Clamp**
- H5228—7" Clamp**
- H5238—8" Clamp**
- H5253—9" Clamp**

These clamps feature lever latches and foam seals, and secure around the rolled ends of fittings and pipe.



Figure 69. Dust collection pipe clamps.

- G2752—4" Rolling Floor Sweep**
- G2753—4" Bench Dust Collection Attachment**
- G2754—4" Floor Dust Collection Attachment**

These attachments are indispensable for collecting dust at machines without a port. The rolling floor sweep is also a convenient way to keep the shop floor or workbench top clean! Designed for use with 4" flexible hose (not included).



Figure 70. Dust collection attachments.

H2443—Universal Adapter

This seven step adapter provides a multitude of dust collection reducing options. Simply cut away unneeded steps with a hacksaw. Outside diameter step sizes include 1", 2", 2.5", 3", 4", 5", and 6". Wall thickness is 1/8".

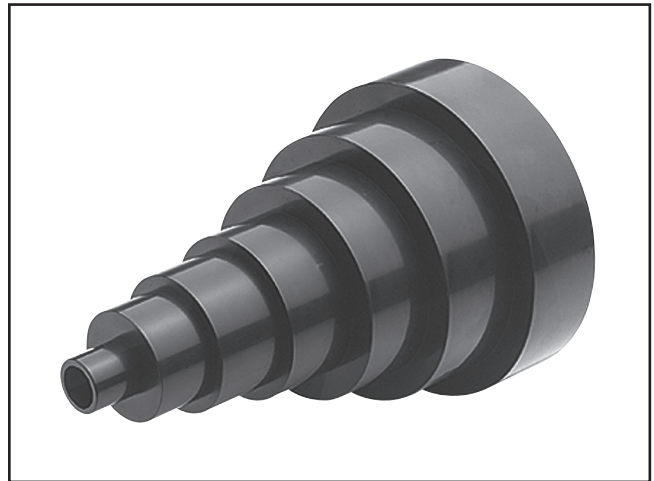

Figure 71. H2443 Universal Adapter.

G0572—Hanging Air Cleaner w/Remote

Unfortunately, not even the best dust collection systems get all the dust. This is why it is extremely important to have one or two air cleaners to claim the fine dust suspended in the air. This model features a convenient remote control, three speeds, an automatic shutoff timer, and a 2-stage filter system (5 micron outer and 1 micron inner). Easily the best value in its class!



Figure 72. G0572 Hanging Air Cleaner.

Call 1-800-523-4777 To Order



SECTION 6: OPERATIONS

Operation Safety

!WARNING

Damage to your eyes, lungs, and ears could result from using this machine without proper protective gear. Always wear safety glasses, a respirator, and hearing protection when operating this machine.



!CAUTION

DO NOT use the dust collector for any other purpose besides collecting dust from connected woodworking machines. A dust collector should **NEVER** be used as a shop vacuum and **IS NOT** a substitute for an air filter system. For safest use, wear a respirator and use an air cleaner in addition to the dust collector.

NOTICE

If you have never used this type of machine or equipment before, **WE STRONGLY RECOMMEND** that you read books, trade magazines, or get formal training before beginning any projects. Regardless of the content in this section, Grizzly Industrial will not be held liable for accidents caused by lack of training.

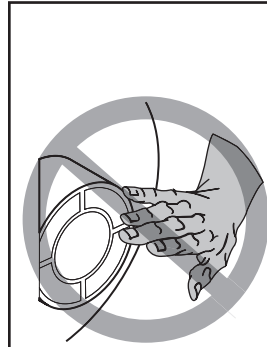

!WARNING

Do **NOT** put hands or small objects near inlet openings during operation. Objects sucked into the inlet will meet with the impeller blade. Failure to heed this warning could result in property damage or personal injury.

General

Operating your Model G0637/G0638 is simple and straightforward. Blast gates located at each of the machines controls the air flow from the woodworking machine to the dust collector. If a machine is not being used, keep the blast gate closed to maintain higher levels of efficiency throughout the system.

Remote Control

The remote control for the Model G0637/G0638 is IR (infrared) rather than RF (radio frequency) to prevent accidental startups by other common RF items like garage door openers.

Because this remote system is IR, the remote control must be pointing directly at the control box with an unobstructed line-of-sight view.

If you place your dust collector in a different room or outside of your shop, you must mount the switch in the shop and wire it through the wall to the dust collector to make use of the remote control.



SECTION 7: MAINTENANCE

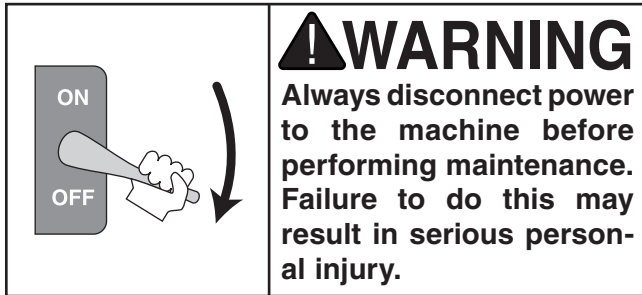

Schedule

For optimum performance from your machine, follow this maintenance schedule and refer to any specific instructions given in this section.

Daily Check:

- Dust collector is completely powered down at the end of use.
- Dust collection drums and bags.
- Loose mounting bolts.
- Pressure leaks.
- Worn or damaged wires.
- Any other condition that would hamper the safe and efficient operation of this machine.

Emptying Drums

Empty the collection drums when they are $\frac{3}{4}$ full or less. If the drums become overfilled, the dust will be sucked into the intake barrel and passed through to the canister filters.

How quickly the drum will fill up is based on the type of work being done at the time:

- Fine dust from a sander or table saw will slowly fill the drums.
- Curly shavings from a planer or jointer will quickly fill the drums.

In the beginning, check your drums regularly to get an idea of how often they need to be emptied.

Cleaning Filters

The Model G0637/G0638 dust collector has a gentle brush system inside the canisters for removing any built-up dust from the filter pleats.

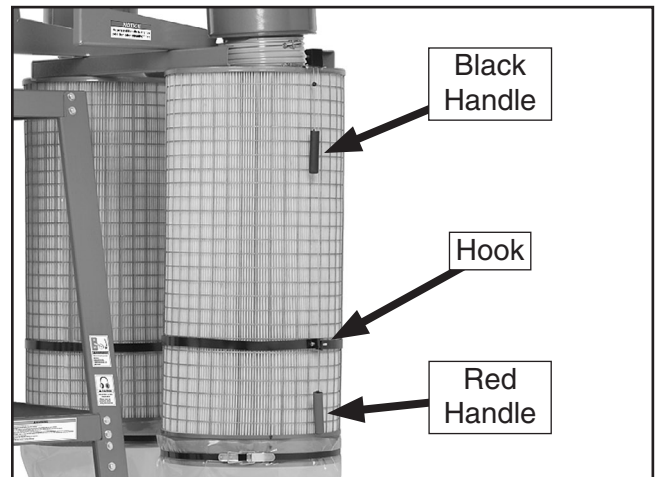
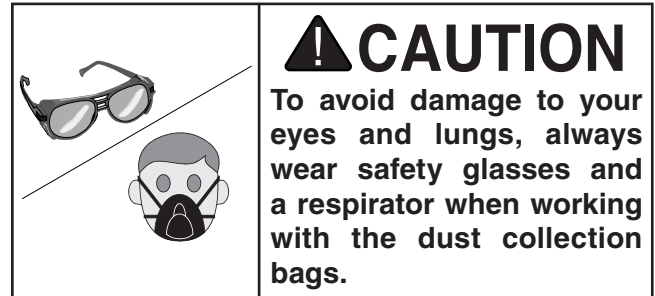

Figure 73. Brush handles for cleaning canister filters.

To clean the filters, pull the red handles down all the way, then pull the black handles down and hook them in place.

Note: Always make sure to leave the red handles in the up position to ensure that the brushes return to their proper position and do not restrict the filter.

For a more thorough cleaning, remove the filters from the dust collector and rinse them with clear water. Allow the filters to air dry. Do not leave the filters in the sun to dry or apply heat to speed the process; heat exposure can damage your filters.



SECTION 8: SERVICE

Review the troubleshooting and procedures in this section to fix or adjust your machine if a problem develops. If you need replacement parts or you are unsure of your repair skills, then feel free to call our Technical Support at (570) 546-9663.

Troubleshooting

Motor & Electrical

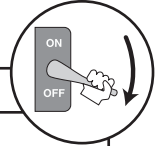

Symptom	Possible Cause	Possible Solution
Machine does not start or a breaker trips.	<ol style="list-style-type: none"> 1. Fuse has blown. 2. Emergency stop push-button is engaged/faulty. 3. Hand-held remote controller is at fault. 4. Receiver is at fault. 5. Motor connection wired incorrectly. 6. Wall fuse/circuit breaker is blown/tripped. 7. Thermal overload relay has tripped. 8. Contactor not getting energized/has burnt contacts. 9. Power supply switched OFF or is at fault. 10. Wiring is open/has high resistance. 11. Motor ON button or ON/OFF switch is at fault. 12. Emergency stop push-panel is stuck/switch is at fault. 13. Transformer is at fault. 14. Computer board is at fault. 15. Inverter/control box is at fault. 16. Motor is at fault. 17. Start delay module is at fault. 	<ol style="list-style-type: none"> 1. Correct short/replace fuse in control box. 2. Rotate clockwise slightly until it pops out/replace it. 3. Replace batteries in hand-held remote controller; stay in line-of-sight view and signal range. 4. Inspect receiver computer board; replace if faulty. 5. Correct motor wiring connections (Pages 46 & 49). 6. Ensure circuit size is suitable for this machine; replace weak breaker. 7. Turn cut-out dial to increase working amps and push the reset pin. Replace if tripped multiple times (weak relay). 8. Test for power on all legs and contactor operation. Replace unit if faulty. 9. Ensure power supply is switched on; ensure power supply has the correct voltage. 10. Check for broken wires or disconnected/corroded connections, and repair/replace as necessary. 11. Replace faulty ON button or ON/OFF switch. 12. Free push-panel from binding; replace faulty switch. 13. Replace transformer. Refer to Page 12 for more detail information. 14. Inspect computer board; replace if faulty. 15. Inspect inverter/control box; replace if faulty. 16. Test/repair/replace. 17. Adjust to correct delay; replace module.
Machine has vibration or noisy operation.	<ol style="list-style-type: none"> 1. Motor or component is loose. 2. Motor mount loose/broken. 3. Machine is incorrectly mounted or sits unevenly. 4. Motor fan is rubbing on fan cover. 5. Motor bearings are at fault. 	<ol style="list-style-type: none"> 1. Inspect/replace stripped or damaged bolts/nuts, and re-tighten with thread locking fluid. 2. Tighten/replace. 3. Tighten/replace anchor studs in floor; relocate/shim machine. 4. Replace dented fan cover; replace loose/damaged fan. 5. Test by rotating shaft; rotational grinding/loose shaft requires bearing replacement.



Dust Collector Operation

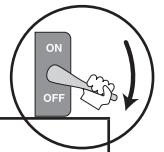

Symptom	Possible Cause	Possible Solution
Loud, repetitious noise, or excessive vibration coming from dust collector.	<ol style="list-style-type: none"> 1. Dust collector is not on a flat surface and wobbles. 2. Impeller is damaged and unbalanced. 3. The motor mounting or housing connections are loose. 4. Impeller is loose on the motor shaft. 5. Motor fan cover is dented, causing the motor fan to hit the cover while spinning. 	<ol style="list-style-type: none"> 1. Stabilize the dust collector. 2. Disconnect dust collector from power, and inspect the impeller for dents, bends, loose fins. Replace impeller if any damage is found. 3. Make sure all fasteners on the dust collector are tight. 4. Replace the motor and impeller as a set if the motor shaft and the impeller hub are damaged. 5. Replace motor fan cover.
Dust collector does not adequately collect dust or chips; poor performance.	<ol style="list-style-type: none"> 1. Dust collection bags are full. 2. Filter is dirty. 3. There is a restriction in the duct line. 4. The dust collector is too far away from the point of suction, or there are too many sharp bends in the ducting. 5. The lumber is wet and dust is not flowing through the ducting smoothly. 6. There is a leak in the ducting, or a series of small leaks, or too many open ports. 7. There are not enough open branch lines at one time, thereby causing a velocity drop in the main line. 8. The ducting and ports are incorrectly sized. 9. The machine dust collection design is inadequate. 10. The dust collector is too small for the dust collection system. 	<ol style="list-style-type: none"> 1. Empty collection bags. 2. Clean filter. 3. Remove dust line from dust collector inlet and unblock the restriction in the duct line. A plumbing snake may be necessary. 4. Relocate the dust collector closer to the point of suction, and rework ducting without sharp bends. Refer to Designing the System, beginning on Page 28. 5. Process lumber with less than 20% moisture content. 6. Rework the ducting to eliminate all leaks. Close dust ports for lines not being used. Refer to Designing the System beginning on Page 28 for more solutions. 7. Open 1 or 2 more blast gates to different branch lines to allow the velocity in the main line to increase. 8. Reinstall correctly sized ducts and fittings. Refer to Designing the System beginning on Page 28 for more solutions. 9. Use a dust collection nozzle on a stand. 10. Install a larger dust collector to power your dust collection system.
Sawdust being blown into the air from the dust collector.	<ol style="list-style-type: none"> 1. Duct clamps or dust collection bags are not properly clamped and secured. 2. Cylinder or funnel seals are loose or damaged. 	<ol style="list-style-type: none"> 1. Re-secure ducts and dust collection bag, making sure duct and bag clamps are tight and completely over the ducts and bags. 2. Retighten all mounting and sealing points, replace damaged gaskets.



Service Log

Date	Approximate Hours Of Use	Service Performed



G0637 Electrical Components

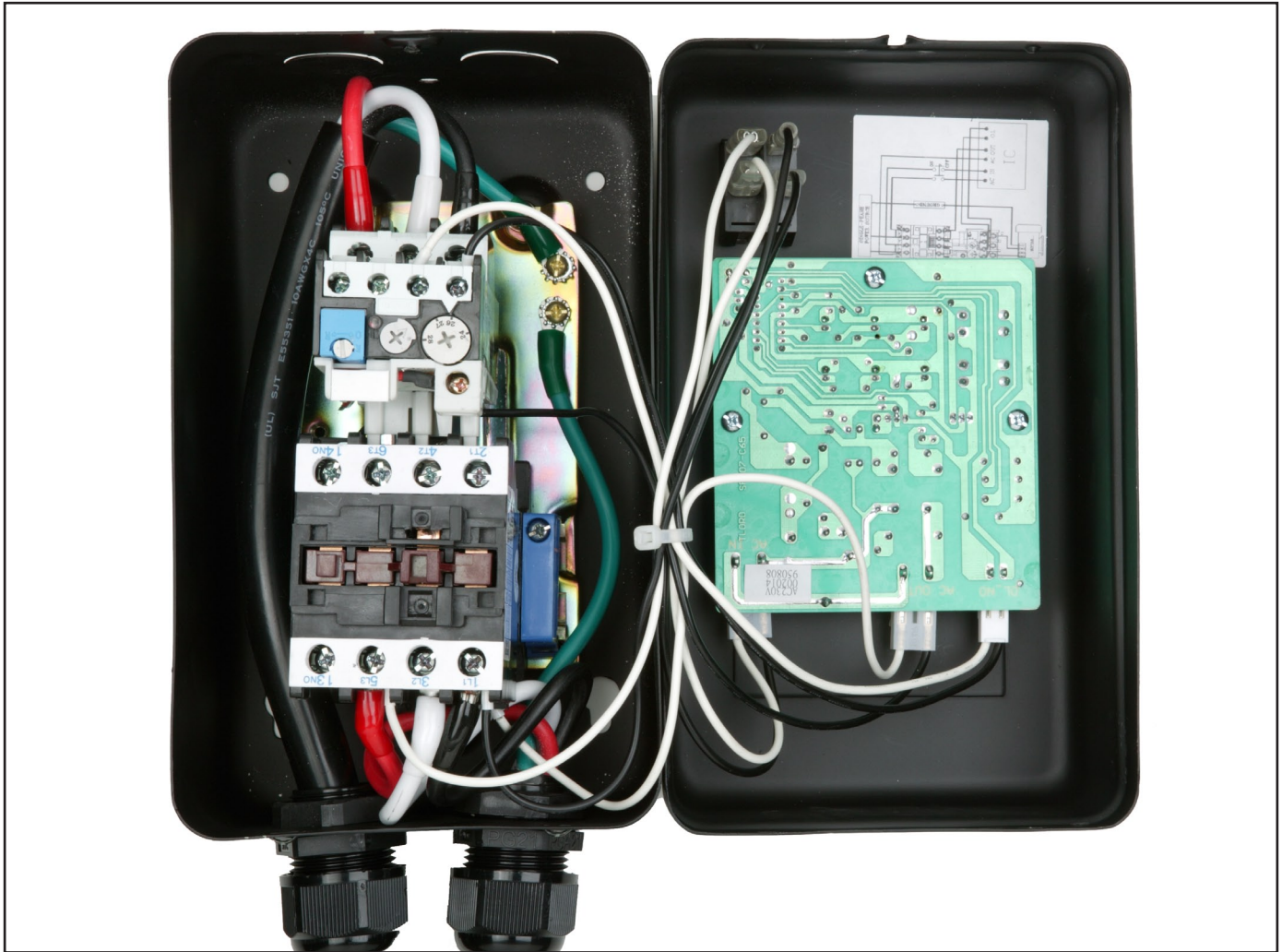

Figure 74. Model G0637 control box.

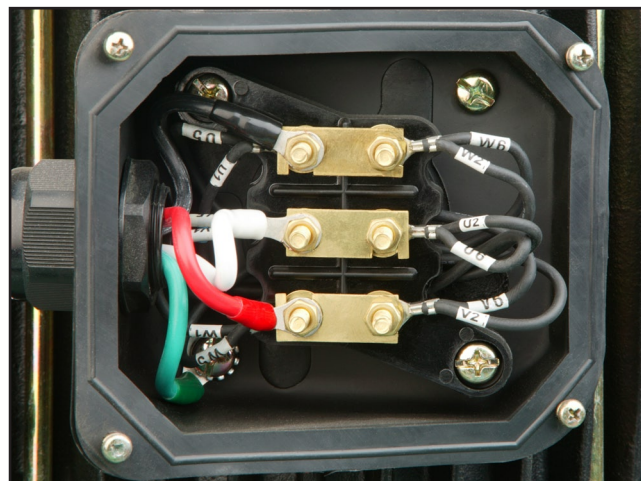

Figure 75. Model G0637 motor wiring (220V).



G0637 Control Box 220 VAC Wiring Diagram



COLOR KEY

BLACK	
WHITE	
GREEN	
RED	

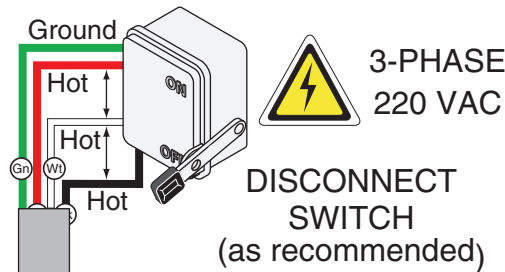

NOTICE
If connecting machine to a phase converter, the manufactured leg must be connected to terminal 3L/2.

NOTICE
If motor rotates in opposite direction, swap any two power source wires at the incoming terminals.

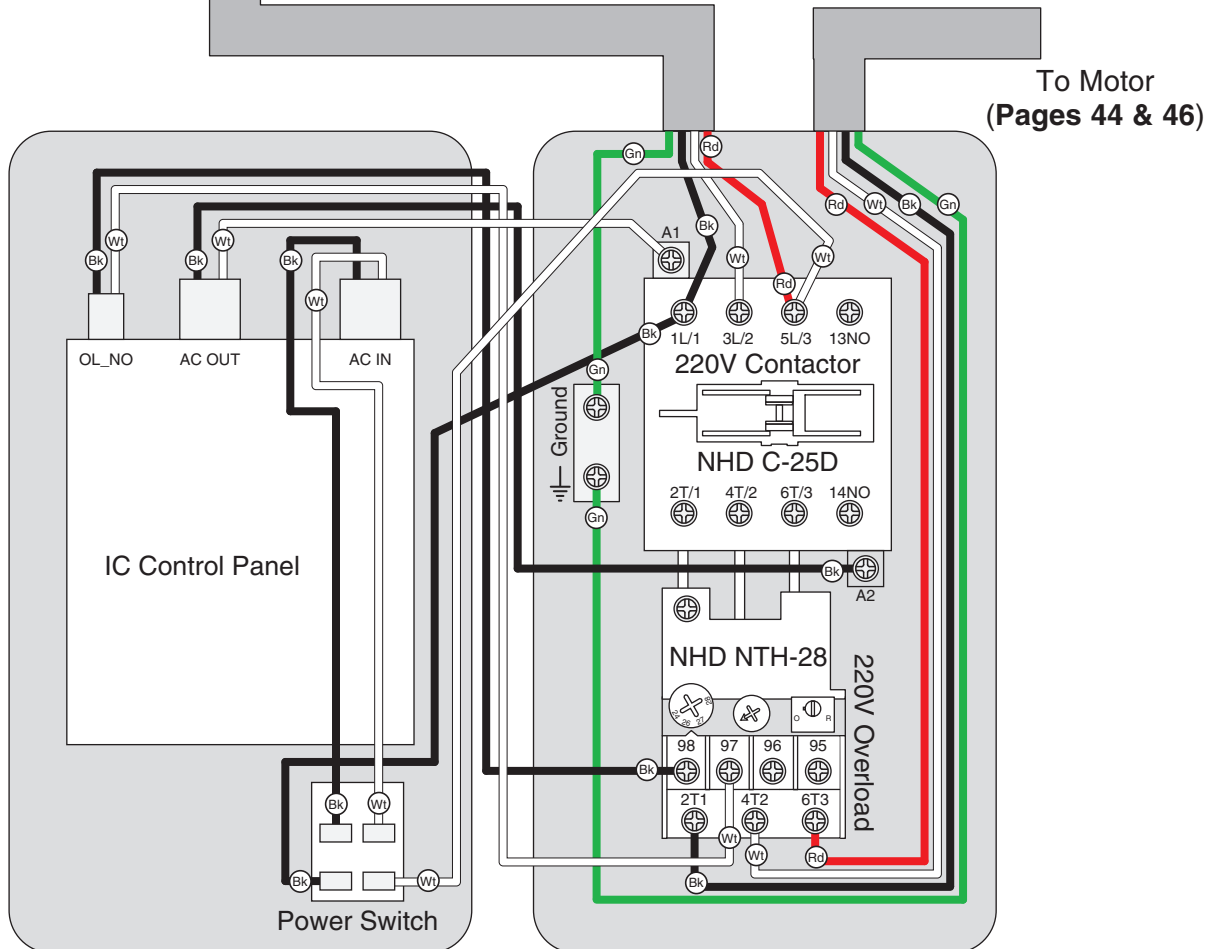

G0637 Motor Wiring Diagram (220V/440V)



COLOR KEY	
BLACK	
WHITE	
GREEN	
RED	

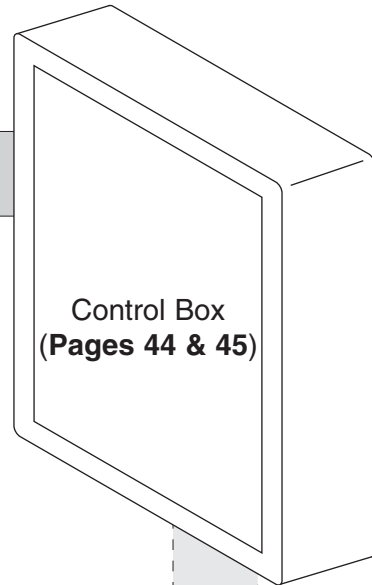

220VAC
(Pre-Wired)

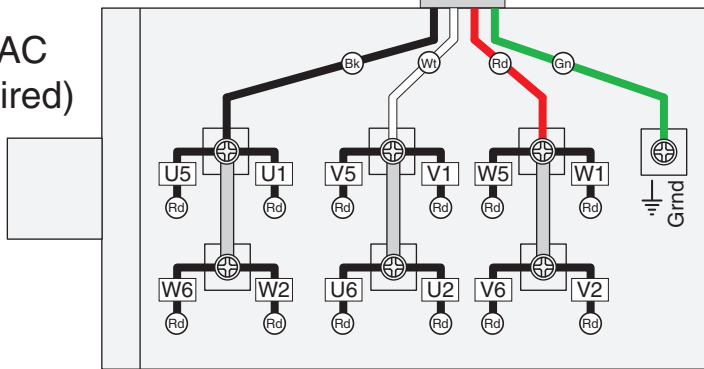

440 VAC, 3-Phase (Optional)

440VAC
(Optional)

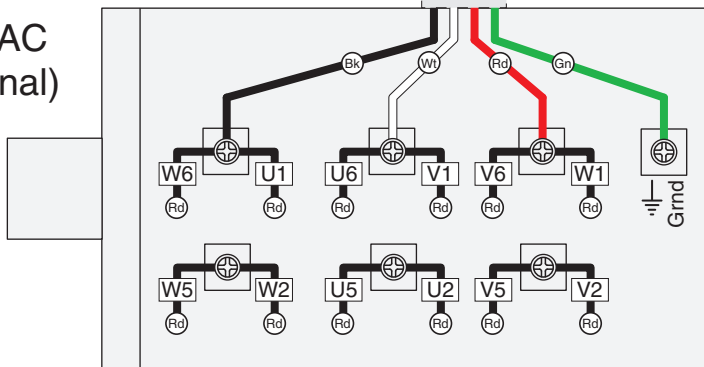

When rewiring to 440V, you must purchase and install the 440V Conversion Kit. Refer to **Page 12** for details.

NOTICE

These motor wiring diagrams are current at the time of printing; however, always use the diagram on the inside of the junction box cover when rewiring your motor!



G0638 Electrical Components

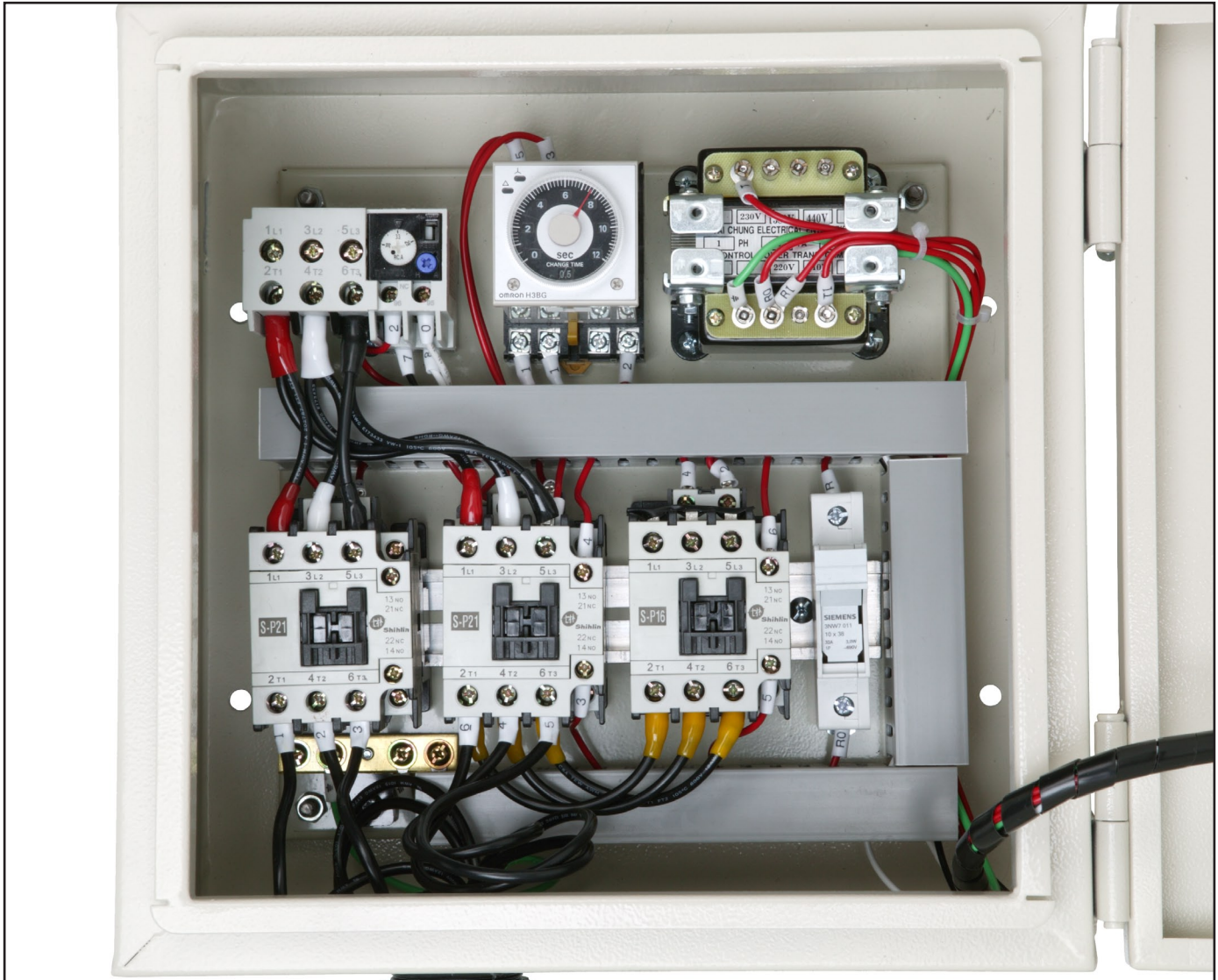

Figure 76. Model G0638 control box.

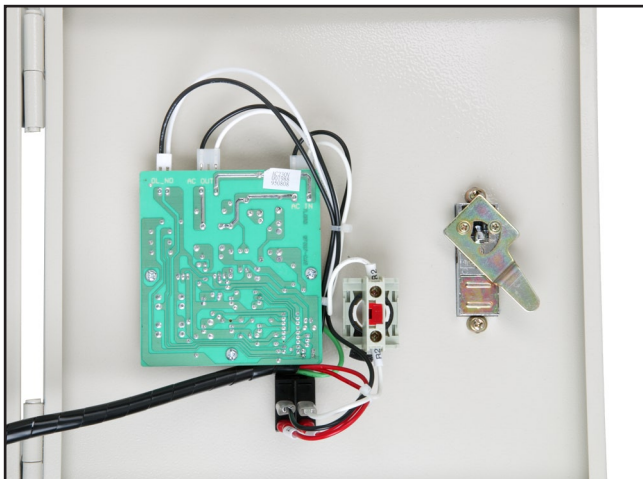

Figure 77. Model G0638 control box cover (shown from back).



Figure 78. Model G0638 motor wiring (220V).



G0638 Control Box 220 VAC Wiring Diagram

⚠ WARNING!
SHOCK HAZARD!
Disconnect power before working on wiring.

NOTICE
If connecting machine to a phase converter, the manufactured leg must be connected to terminal 3L/2.

COLOR KEY

- BLACK — Bk —
- WHITE — Wt —
- GREEN — Gr —
- RED — Rd —

View this wiring diagram in color at www.grizzly.com.

NOTICE
If motor rotates in opposite direction, swap any two power source wires at the incoming terminals.

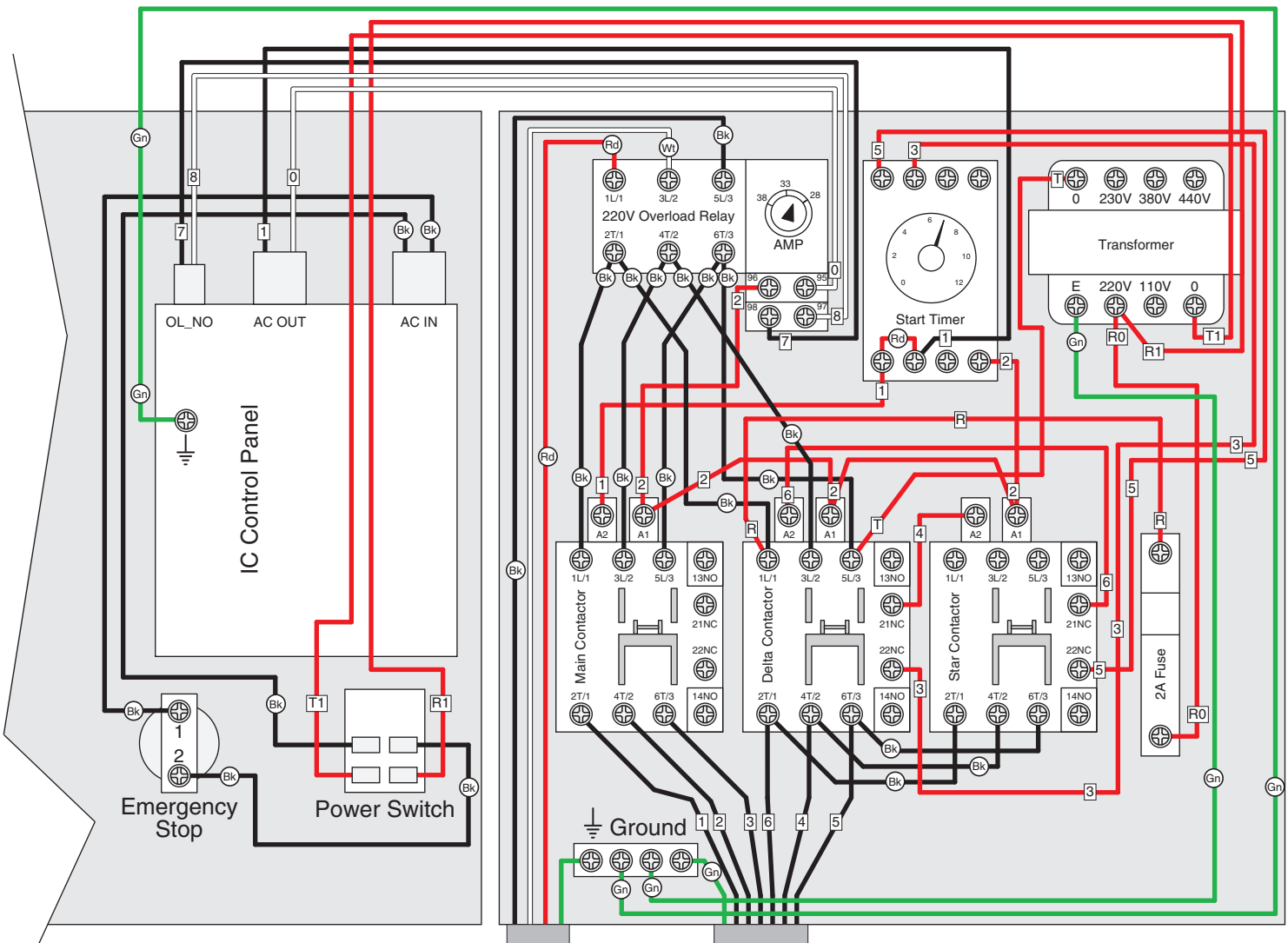

3-PHASE
220 VAC

DISCONNECT
SWITCH
(as recommended)

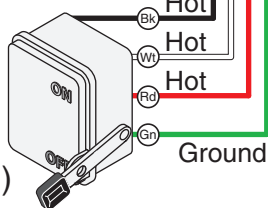

To Motor
(Pages 47 & 49)



G0638 Motor Wiring Diagram (220V/440V)



COLOR KEY

BLACK	
WHITE	
GREEN	
RED	

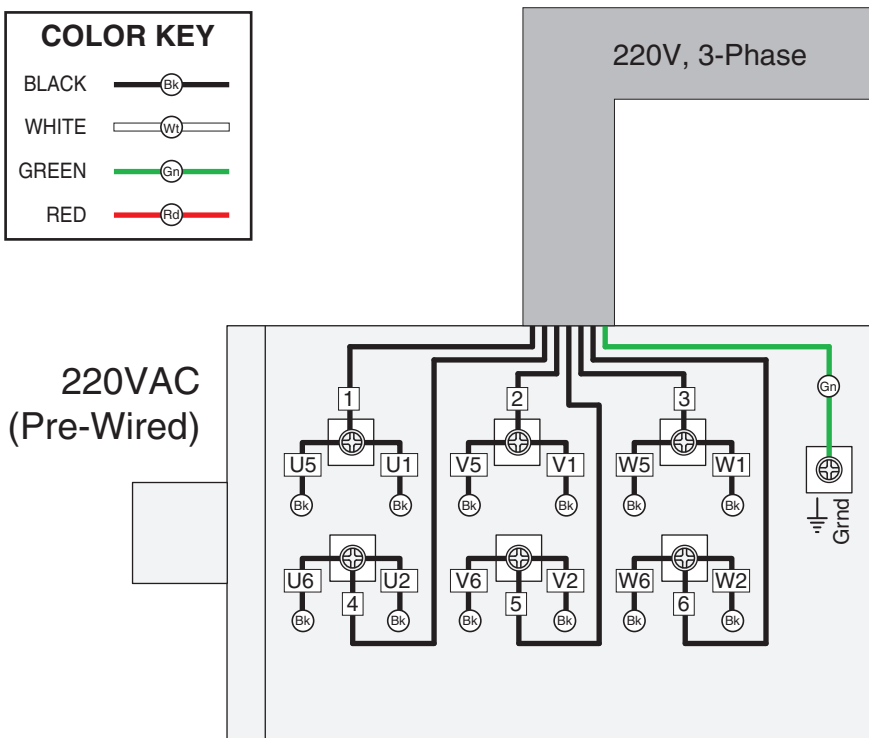
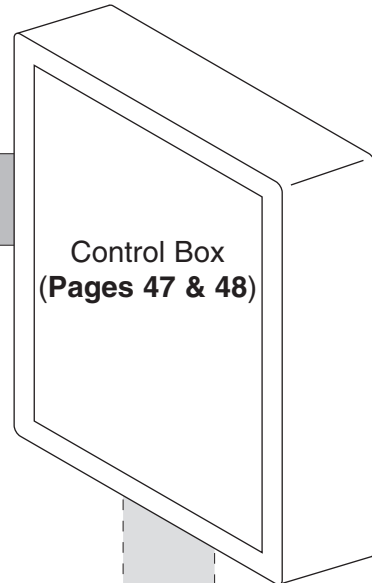

When rewiring to 440V, you must purchase and install the 440V Conversion Kit. Refer to **Page 12** for details.

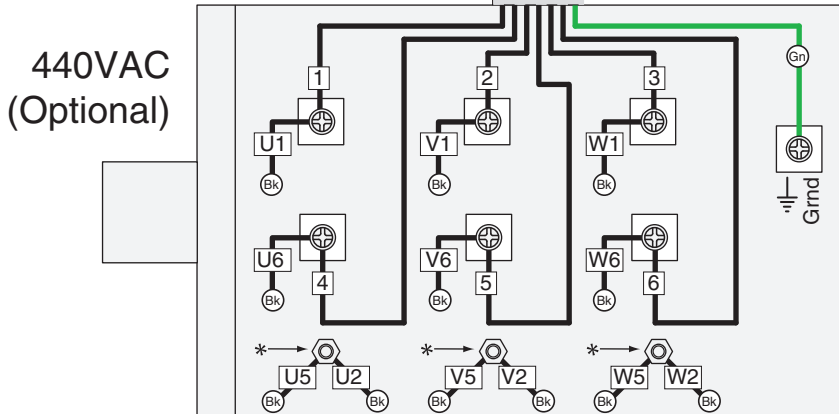
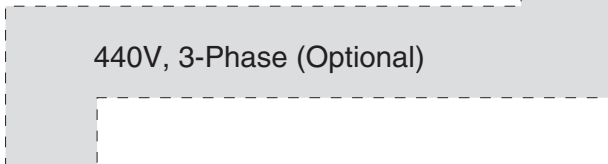

* Safely cover wire connections with electrical tape

NOTICE
These motor wiring diagrams are current at the time of printing; however, always use the diagram on the inside of the junction box cover when rewiring your motor!



Parts Breakdown

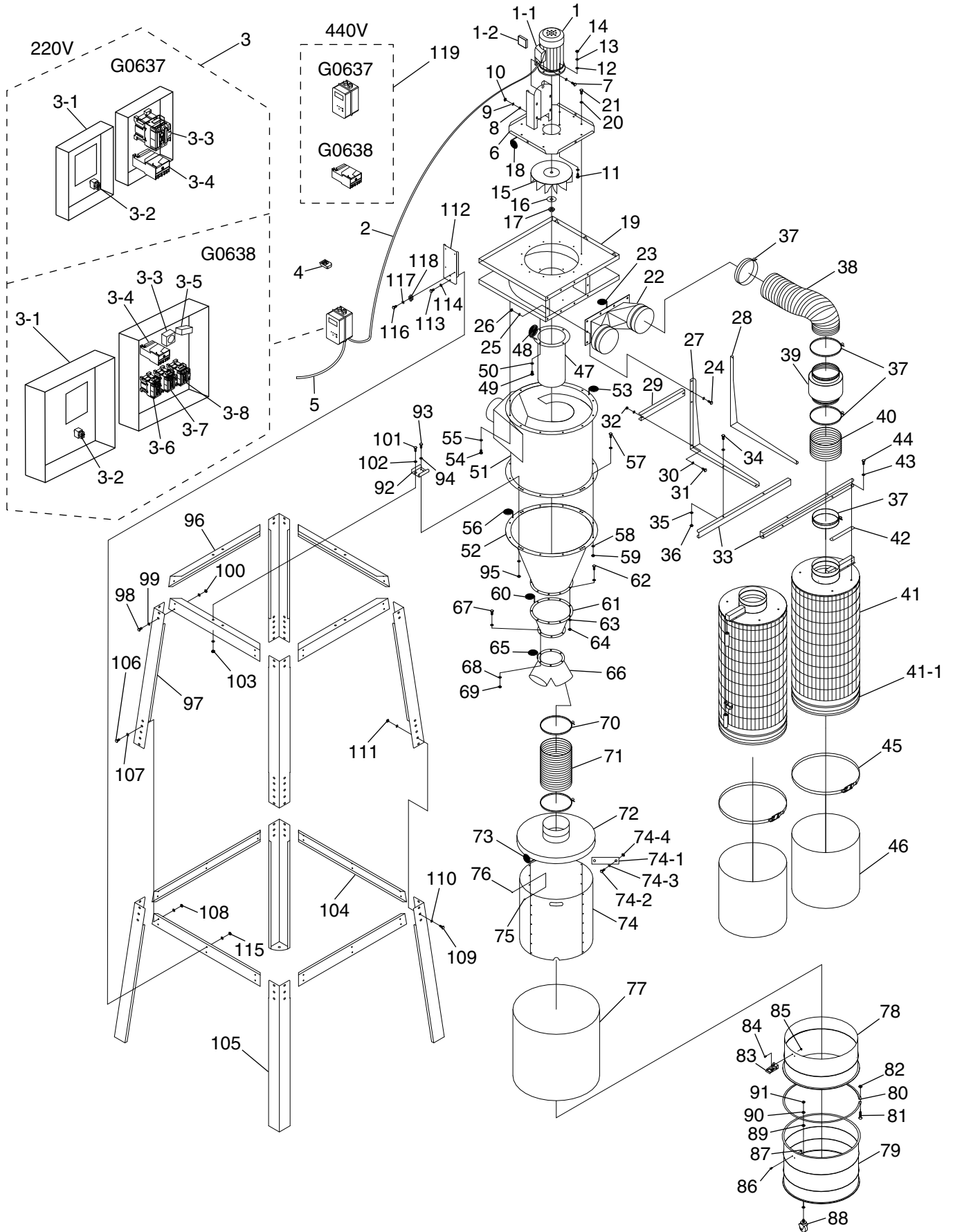

Parts List

REF	PART #	DESCRIPTION
1	P0637001	MOTOR 7.5HP 220V/3-PHASE (G0637)
1	P0638001	MOTOR 10HP 220V/3-PHASE (G0638)
1-1	P0637001-1	MOTOR JUNCTION BOX
1-2	P0637001-2	MOTOR JUNCTION BLOCK
2	P0637002	MOTOR CORD 10AWG (G0637)
2	P0638002	MOTOR CORD 12AWG (G0638)
3	P0637003	CONTROL BOX 220V (G0637)
3	P0638003	CONTROL BOX 220V (G0638)
3-1	P0637003-1	CONTROL BOX CABINET W/IC BOARD 220V (G0637)
3-1	P0638003-1	CONTROL BOX CABINET W/IC BOARD (G0638)
3-2	P0637003-2	POWER SWITCH (G0637)
3-2	P0638003-2	POWER SWITCH (G0638)
3-3	P0637003-3	CONTACTOR 220V (G0637)
3-3	P0638003-3	START TIMER OMRON H3BG 0-12 SEC (G0638)
3-4	P0637003-4	OVERLOAD RELAY 220V (G0637)
3-4	P0638003-4	OVERLOAD RELAY 220V SHIHLIN TH-P20 28-38A (G0638)
3-5	P0638003-5	TRANSFORMER (G0638)
3-6	P0638003-6	CONTACTOR SHIHLIN S-P21 (G0638)
3-7	P0638003-7	CONTACTOR SHIHLIN S-P21 (G0638)
3-8	P0638003-8	CONTACTOR SHIHLIN S-P16 (G0638)
4	P0637004	REMOTE CONTROLLER (G0637)
4	P0638004	REMOTE CONTROLLER (G0638)
5	P0637005	POWER CORD 10AWG (G0637)
6	P0637006	MOTOR BASE
7	PB16	HEX BOLT 3/8-16 X 1-1/2
8	PW02	FLAT WASHER 3/8
9	PLW04	LOCK WASHER 3/8
10	PN08	HEX NUT 3/8-16
11	PB55	HEX BOLT 1/2-13 X 1-1/2
12	PW01	FLAT WASHER 1/2
13	PLW07	LOCK WASHER 1/2
14	PN13	HEX NUT 1/2-13
15	P0637015	IMPELLER 18" (G0637)
15	P0638015	IMPELLER 18-1/2" (G0638)
16	PW13	FLAT WASHER 3/4 (G0637)
16	P0638016	FLAT WASHER 1-1/6 (G0638)
17	P0637017	HEX NUT 3/4-10 (LH) (G0637)
17	P0638017	HEX NUT 1-1/16-8 (LH) (G0638)
18	P0637018	GASKET 3 X 6 X 1700MM
19	P0637019	BLOWER
20	PW07	FLAT WASHER 5/16
21	PB07	HEX BOLT 5/16-18 X 3/4
22	P0637022	OUTLET PORT
23	P0637023	GASKET 3 X 6 X 1100MM
24	PB03	HEX BOLT 5/16-18 X 1

REF	PART #	DESCRIPTION
25	PW07	FLAT WASHER 5/16
26	PN02	HEX NUT 5/16-18
27	P0637027	FILTER L-BRACE RIGHT
28	P0637028	FILTER L-BRACE LEFT
29	P0637029	FILTER BRACE SUPPORT SHORT
30	PB21	FLAT WASHER 3/8
31	PW02	HEX BOLT 3/8-16 X 3/4
32	PN08	HEX NUT 3/8-16
33	P0637033	FILTER BRACE SUPPORT LONG
34	PB21	HEX BOLT 3/8-16 X 3/4
35	PW02	FLAT WASHER 3/8
36	PN08	HEX NUT 3/8-16
37	P0637037	HOSE CLAMP 8"
38	P0637038	FLEXIBLE DUCT 8 X 31-1/2"
39	P0637039	NOISE MUFFLER 8"
40	P0637040	FLEXIBLE DUCT 8 X 4-3/4"
41	P0637041	CANISTER FILTER 510 X 1200MM (G0637)
41	P0638041	CANISTER FILTER 510 X 1500MM (G0638)
41-1	P0637041-1	GASKET 25 X 3 X 1300MM
42	P0637042	RUBBER BRACE GASKET
43	PW07	FENDER WASHER 5/16
44	PB07	HEX BOLT 5/16-18 X 3/4
45	P0637045	FILTER BAG CLAMP 510MM
46	P0637046	COLLECTION BAG 510 X 600MM
47	P0637047	INTAKE CYLINDER
48	P0637048	GASKET 3 X 6 X 1800MM
49	PB07	HEX BOLT 5/16-18 X 3/4
50	PW07	FLAT WASHER 5/16
51	P0637051	INTAKE BARREL
52	P0637052	CYCLONE FUNNEL LARGE
53	P0637053	GASKET 3 X 6 X 2500MM
54	PB07	HEX BOLT 5/16-18 X 3/4
55	PW07	FLAT WASHER 5/16
56	P0637056	GASKET 3 X 6 X 2500MM
57	PB12	HEX BOLT 5/16-18 X 1-1/4
58	PW07	FLAT WASHER 5/16
59	PN02	HEX NUT 5/16-18
60	P0637060	GASKET 3 X 6 X 2200MM
61	P0637061	CYCLONE FUNNEL SMALL
62	PB12	HEX BOLT 5/16-18 X 1-1/4
63	PW07	FLAT WASHER 5/16
64	PN02	HEX NUT 5/16-18
65	P0637065	GASKET 3 X 6 X 735MM
66	P0637066	FUNNEL PORT
67	PB12	HEX BOLT 5/16-18 X 1-1/4



Parts List

REF	PART #	DESCRIPTION
68	PW07	FLAT WASHER 5/16
69	PN02	HEX NUT 5/16-18
70	P0637070	HOSE CLAMP 9"
71	P0637071	FLEXIBLE DUCT 9 x 25-1/2"
72	P0637072	COLLECTION DRUM LID
73	P0637073	GASKET 10 X 50 X 2000MM
74	P0637074	BAG HOLDER
74-1	P0637074-1	RUBBER HANDLE
74-2	PB02	HEX BOLT 1/4-20 X 5/8
74-3	PW06	FLAT WASHER 1/4
74-4	PN05	HEX NUT 1/4-20
75	PS06	PHLP HD SCR 10-24 X 3/8
76	PN07	HEX NUT 10-24
77	P0637077	COLLECTION BAG 640 X 1200MM
78	P0637078	COLLECTION DRUM UPPER
79	P0637079	COLLECTION DRUM LOWER
80	P0637080	COLLECTION DRUM CLAMP
81	PB04	HEX BOLT 5/16-18 X 3
82	PN02	HEX NUT 5/16-18
83	P0637083	COLLECTION DRUM LID LATCH
84	PS06	PHLP HD SCR 10-24 X 3/8
85	PN07	HEX NUT 10-24
86	PS06	PHLP HD SCR 10-24 X 3/8
87	PN07	HEX NUT 10-24
88	P0637088	CASTER 2"
89	PW02	FLAT WASHER 3/8
90	PLW04	LOCK WASHER 3/8
91	PN08	HEX NUT 3/8-16
92	P0637092	CYCLONE MOUNTING BRACKET
93	PB24	HEX BOLT 3/8-16 X 1-1/4
94	PW02	FLAT WASHER 3/8

REF	PART #	DESCRIPTION
95	PLN01	LOCK NUT 3/8-16
96	P0637096	UPPER STAND BRACE
97	P0637097	UPPER STAND LEG
98	PB21	HEX BOLT 3/8-16 x 3/4
99	PW02	FLAT WASHER 3/8
100	PLN01	LOCK NUT 3/8-16
101	PB21	HEX BOLT 3/8-16 X 3/4
102	PW02	FLAT WASHER 3/8
103	PLN01	LOCK NUT 3/8-16
104	P0637104	LOWER STAND BRACE
105	P0637105	LOWER STAND LEG
106	PB21	HEX BOLT 3/8-16 X 3/4
107	PW02	FLAT WASHER 3/8
108	PLN01	LOCK NUT 3/8-16
109	PB21	HEX BOLT 3/8-16 X 3/4
110	PW02	FLAT WASHER 3/8
111	PLN01	LOCK NUT 3/8-16
112	P0637112	CONTROL BOX BRACKET (G0637)
112	P0638112	CONTROL BOX BRACKET (G0638)
113	PB21	HEX BOLT 3/8-16 X 3/4
114	PW02	FLAT WASHER 3/8
115	PN08	HEX NUT 3/8-16
116	PS06	PHLP HD SCR 10-24 X 3/8 (G037)
116	PS11M	PHLP HD SCR M6-1 X 16 (G0638)
117	PW03	FLAT WASHER #10 (G0637)
117	PW03M	FLAT WASHER 6MM (G0638)
118	PN07	HEX NUT 10-24 (G0637)
118	PN01M	HEX NUT M6-1 (G0638)
119	P0637119	440V CONVERSION KIT (G0637)
119	P0638119	440V CONVERSION KIT (G0638)



Label Placement

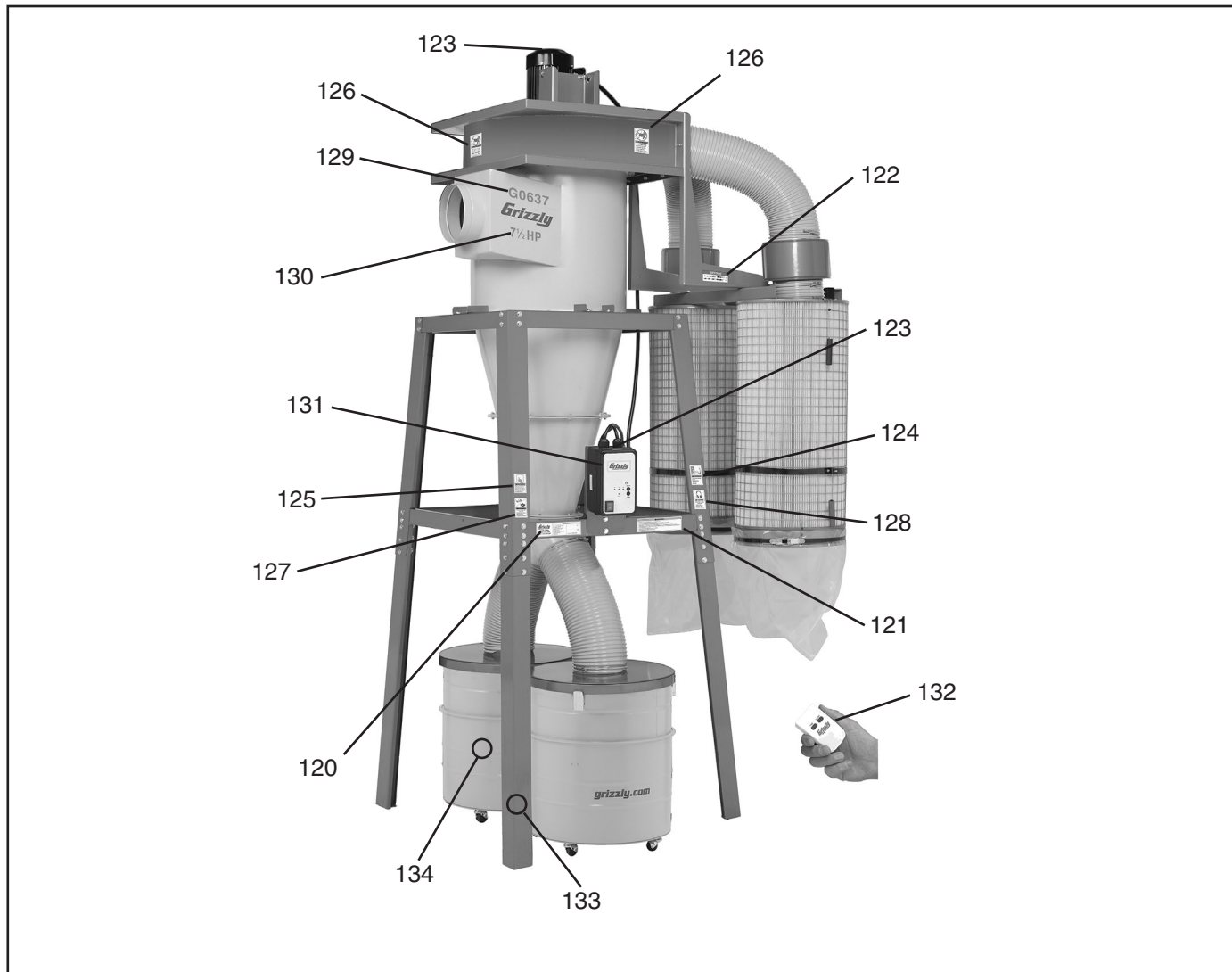

REF	PART #	DESCRIPTION
120	P0637120	MACHINE ID LABEL (G0637)
120	P0638120	MACHINE ID LABEL (G0638)
121	P0637121	GENERAL WARNINGS LABEL
122	P0637122	RED HANDLE NOTICE LABEL
123	PLABEL-14	ELECTRICITY LABEL
124	P0637124	DISCONNECT POWER LABEL
125	PLABEL-12	READ MANUAL LABEL
126	P0637126	HANDS/OUTLET LABEL
127	P0637127	EYE/LUNG LABEL
128	PLABEL-15	HEARING HAZARD LABEL

REF	PART #	DESCRIPTION
129	P0637129	MODEL NUMBER LABEL (G0637)
129	P0638129	MODEL NUMBER LABEL (G0638)
130	P0637130	HORSEPOWER LABEL (G0637)
130	P0638130	HORSEPOWER LABEL (G0638)
131	P0637131	CONTROL PANEL LABEL (G0637)
131	P0638131	CONTROL PANEL LABEL (G0638)
132	P0637132	REMOTE CONTROL LABEL
133	PPAINT-1	GRIZZLY GREEN TOUCHUP PAINT
134	PPAINT-11	GRIZZLY PUTTY TOUCHUP PAINT

WARNING

Safety labels warn about machine hazards and ways to prevent injury. The owner of this machine **MUST** maintain the original location and readability of the labels on the machine. If any label is removed or becomes unreadable, **REPLACE** that label before using the machine again. Contact Grizzly at (800) 523-4777 or www.grizzly.com to order new labels.



WARRANTY AND RETURNS

Grizzly Industrial, Inc. warrants every product it sells for a period of **1 year** to the original purchaser from the date of purchase. This warranty does not apply to defects due directly or indirectly to misuse, abuse, negligence, accidents, repairs or alterations or lack of maintenance. This is Grizzly's sole written warranty and any and all warranties that may be implied by law, including any merchantability or fitness, for any particular purpose, are hereby limited to the duration of this written warranty. We do not warrant or represent that the merchandise complies with the provisions of any law or acts unless the manufacturer so warrants. In no event shall Grizzly's liability under this warranty exceed the purchase price paid for the product and any legal actions brought against Grizzly shall be tried in the State of Washington, County of Whatcom.

We shall in no event be liable for death, injuries to persons or property or for incidental, contingent, special, or consequential damages arising from the use of our products.

To take advantage of this warranty, contact us by mail or phone and give us all the details. We will then issue you a "Return Number," which must be clearly posted on the outside as well as the inside of the carton. We will not accept any item back without this number. Proof of purchase must accompany the merchandise.

The manufacturers reserve the right to change specifications at any time because they constantly strive to achieve better quality equipment. We make every effort to ensure that our products meet high quality and durability standards and we hope you never need to use this warranty.

Please feel free to write or call us if you have any questions about the machine or the manual.

Thank you again for your business and continued support. We hope to serve you again soon.





WARRANTY CARD

Name _____

Street _____

City _____ State _____ Zip _____

Phone # _____ Email _____ Invoice # _____

Model # _____ Order # _____ Serial # _____

The following information is given on a voluntary basis. It will be used for marketing purposes to help us develop better products and services. **Of course, all information is strictly confidential.**

1. How did you learn about us?

- Advertisement
- Card Deck
- Friend
- Website
- Catalog
- Other:

2. Which of the following magazines do you subscribe to?

- | | | |
|---|--|---|
| <input type="checkbox"/> Cabinet Maker | <input type="checkbox"/> Popular Mechanics | <input type="checkbox"/> Today's Homeowner |
| <input type="checkbox"/> Family Handyman | <input type="checkbox"/> Popular Science | <input type="checkbox"/> Wood |
| <input type="checkbox"/> Hand Loader | <input type="checkbox"/> Popular Woodworking | <input type="checkbox"/> Wooden Boat |
| <input type="checkbox"/> Handy | <input type="checkbox"/> Practical Homeowner | <input type="checkbox"/> Woodshop News |
| <input type="checkbox"/> Home Shop Machinist | <input type="checkbox"/> Precision Shooter | <input type="checkbox"/> Woodsmith |
| <input type="checkbox"/> Journal of Light Cont. | <input type="checkbox"/> Projects in Metal | <input type="checkbox"/> Woodwork |
| <input type="checkbox"/> Live Steam | <input type="checkbox"/> RC Modeler | <input type="checkbox"/> Woodworker West |
| <input type="checkbox"/> Model Airplane News | <input type="checkbox"/> Rifle | <input type="checkbox"/> Woodworker's Journal |
| <input type="checkbox"/> Modeltec | <input type="checkbox"/> Shop Notes | <input type="checkbox"/> Other: |
| <input type="checkbox"/> Old House Journal | <input type="checkbox"/> Shotgun News | |

3. What is your annual household income?

- \$20,000-\$29,000
- \$30,000-\$39,000
- \$40,000-\$49,000
- \$50,000-\$59,000
- \$60,000-\$69,000
- \$70,000+

4. What is your age group?

- 20-29
- 30-39
- 40-49
- 50-59
- 60-69
- 70+

5. How long have you been a woodworker/metalworker?

- 0-2 Years
- 2-8 Years
- 8-20 Years
- 20+ Years

6. How many of your machines or tools are Grizzly?

- 0-2
- 3-5
- 6-9
- 10+

7. Do you think your machine represents a good value? Yes No

8. Would you recommend Grizzly Industrial to a friend? Yes No

9. Would you allow us to use your name as a reference for Grizzly customers in your area?
Note: We never use names more than 3 times. Yes No

10. Comments: _____

CUT ALONG DOTTED LINE

FOLD ALONG DOTTED LINE



Place Stamp Here



GRIZZLY INDUSTRIAL, INC.
P.O. BOX 2069
BELLINGHAM, WA 98227-2069



FOLD ALONG DOTTED LINE

Send a Grizzly Catalog to a friend:

Name _____
Street _____
City _____ State _____ Zip _____

TAPE ALONG EDGES--PLEASE DO NOT STAPLE

grizzly.com

TOOL WEBSITE

Buy Direct and Save with Grizzly® – Trusted, Proven and a Great Value!

*Visit Our Website Today And Discover
Why Grizzly® Is The Industry Leader!*

- SECURE ORDERING
- ORDERS SHIPPED WITHIN 24 HOURS
- E-MAIL RESPONSE WITHIN ONE HOUR

-OR-

Call Today For A **FREE**
Full Color Catalog

1-800-523-4777

